



FPGWORLD.COM

# CUSTOM

## McDONALD'S 900 HORIZONTAL SPLIT CONTROLLED AMBIENT/REFRIGERATED

MODEL	IL-MD-900-REF-SQ-A001	-A002
RANGE	McDONALD'S	
INSTALLATION	IN-COUNTER/FREESTANDING	
FRONT	SQUARE/FIXED FRONT	
TOP TEMP.	CONTROLLED AMBIENT	
BOTTOM TEMP.	REFRIGERATED	
REFRIGERATION	INTEGRAL, R513A	
TOP SHELF	FIXED DOUBLE GLAZED SAFETY GLASS	
BOTTOM SHELF	BLACK ACRYLIC	BAMBOO
BASE	BLACK ACRYLIC	BAMBOO
HEIGHT	1353mm	
WIDTH	900mm	
DEPTH	814mm	

CORE PRODUCT TEMPERATURE	+16°C – +18°C
	+2°C – +4°C
ENVIRONMENTAL TEST CONDITIONS	CLIMATE CLASS 3 25°C / 60% RH
CABINET CLASSIFICATION BOTTOM DISPLAY	3M1

### FEATURES

- High energy efficiency: **0.35 kWh per hour (average)**
- 50,000 hour LED lighting at 2758 lumens/m to cabinet top and all levels of display
- Sliding doors (staff side) and fixed front (customer side)
- Unique shelf mounted ticket strip front and rear

#### Controlled Ambient Top Display

- Controlled Ambient zone maintains +16°C- +18°C core product temperature with up to 60 door openings per hour**
- Fixed shelf with PVC core to insulate the top display from the refrigerated bottom display

#### Refrigerated Bottom Display

- Refrigerated zone maintains +2°C - +4°C core product temperature with up to 60 door openings per hour**
- Height adjustable shelf up to 50mm with black acrylic or bamboo shelf trays

#### Operational Excellence

- High internal humidity maintains and extends product shelf life
- Fully double glazed glass for energy efficiency
- Rear deck assembly with 2 x tong holders
- Freeflow air technology (no front counter vents required)
- Auto condensate removal (ACR)
- Adjustable 150mm feet (+30mm adjustment)



IL-MD-900-REF-SQ-A001

Showing : Custom McDonald's horizontal split controlled ambient/refrigerated 900mm with fixed double glazed top shelf, adjustable black acrylic bottom shelf and black acrylic base



IL-MD-900-REF-SQ-A002

Showing : Custom McDonald's horizontal split controlled ambient/refrigerated 900mm with fixed double glazed top shelf, adjustable bamboo bottom shelf and bamboo base



Please contact FPG to discuss your requirements for meeting country-specific standards.

FPGWORLD.COM



FPGWORLD.COM

# CUSTOM

## McDONALD'S 900 HORIZONTAL SPLIT CONTROLLED AMBIENT/REFRIGERATED

### REFRIGERATION DATA

	CORE PRODUCT TEMPERATURE	ENVIRONMENTAL TEST CONDITIONS	REFRIGERATION	REFRIGERANT	REFRIGERANT CHARGE	CONDENSATE REMOVAL
TOP DISPLAY	+16°C - +18°C	Climate Class 3 - 25°C / 60% RH	Integral	R513A	See serial label	ACR
BOTTOM DISPLAY	+2°C - +4°C					

### ELECTRICAL DATA

MODEL	VOLTAGE	PHASE	CURRENT	E24H (kWh)	kWh per hour (average)	IP RATING	MAINS		LED LIGHTING	
							CONNECTION	CONNECTION PLUG <sup>1</sup>	HOURS	COLOUR
IL-MD-900-REF-SQ-XXXX	220-240 V	Single	4.3 A	8.4	0.35	IP 22	3 metre 3 core cable	10 amp 3 pin plug	50,000	Natural

<sup>1</sup>Please advise country to change plug specification.

### CAPACITY, ACCESS & CONSTRUCTION

	DISPLAY AREA	LEVELS	ACCESS FRONT	ACCESS REAR	DOOR OPENINGS @ +2°C - +4°C	CHASSIS CONSTRUCTION
TOP DISPLAY	0.45 m <sup>2</sup>	Base only	Fixed front	Sliding doors	60 per hour	Mild & stainless steel Black & natural anodised aluminium
BOTTOM DISPLAY	0.62 m <sup>2</sup>	1 Shelf + Base				

### DIMENSIONS

MODEL	H x W x D mm (Uncrated)	MASS (Uncrated)
IL-MD-900-REF-SQ-XXXX	1353 x 900 x 814	180 kg

Crated weights and dimensions vary. Please contact us for information on your shipment.

#### Installation note:

Model cutout dimensions: IL-MD-900-REF-SQ-XXXX models require 905 x 670mm benchtop cutout. Joinery height 680mm (see product manual for installation guide).

**UNOBSTRUCTED AIRFLOW MUST BE MAINTAINED TO ENSURE UNIT PERFORMANCE AND TO MAINTAIN WARRANTY.**

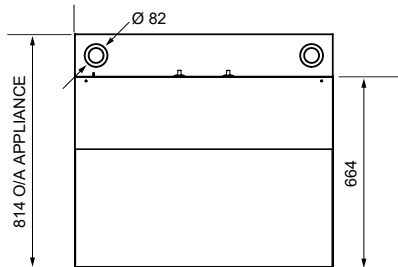

PLAN VIEW

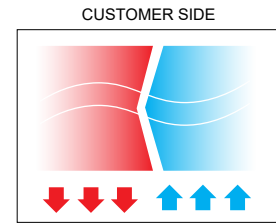

PLAN VIEW - AIRFLOW  
FREEFLOW AIR TECHNOLOGY

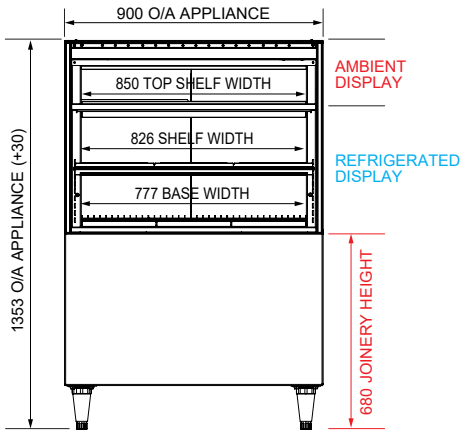

FRONT ELEVATION

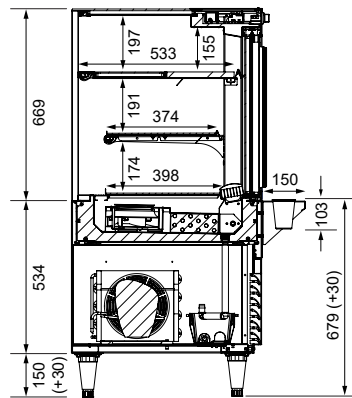

SECTION VIEW

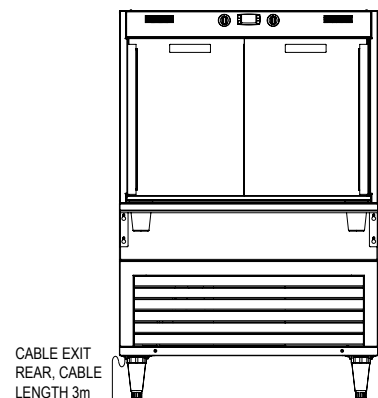

REAR ELEVATION

CABLE EXIT  
REAR, CABLE  
LENGTH 3m

More information including technical data and installation guidelines is available from the Product Manual.

In line with our policy to continually develop, improve and support our products, Future Products Group Ltd reserves the right to change specifications and design without notice.

Have a question? Please email us at [sales@fpgworld.com](mailto:sales@fpgworld.com) or visit [www.fpgworld.com](http://www.fpgworld.com) for full contact details for your region.



Worldwide  
contact  
details: