

MODELS
IL-7EL-AT-B1xx-00
PRODUCT MANUAL 33972
REV A NOV 2024



CUSTOM

7-ELEVEN TOWER CABINETS
FREESTANDING
REFRIGERATED: R290 **VSD**



WIDTH: 800mm
HINGED FRONT DOORS

CUSTOM

7-ELEVEN TOWER CABINETS
FREESTANDING/REFRIGERATED

**Copyright © NOV 2024 Future Products Group Limited.
All rights reserved.**

No part of this publication may be reproduced, stored in a retrieval system, or transmitted in any form or by any means, electronic, mechanical, photocopying, recording or otherwise, without the prior written permission of Future Products Group Ltd.

Warnings

Operational Safety

This appliance is not intended for use by young children or infirm persons, unless they have been adequately supervised by a responsible person, to ensure that they can use the appliance safely.

Young children should be supervised, to ensure that they do not play with the appliance.

Water

THIS UNIT IS NOT WATERPROOF. DO NOT USE A WATER JET SPRAY TO CLEAN THE INTERIOR OR EXTERIOR OF THIS CABINET.

Caution

Do not store explosive substances, such as aerosol cans with flammable propellant, in this appliance.

Mains Supply Cord

If the supply cord is damaged, it must be replaced by the manufacturer, its service agent or similarly qualified persons, in order to avoid a hazard.

Specialist Disposal

Specialist disposal procedures are required for the safe removal of refrigerant gasses and potentially flammable foam materials.

Pentane, Dimethyl Ether, Isobutene, Butane and Propane may be present.

Hazardous Substances

The cabinet does not contain any of the following, in its construction:

Asbestos

PCBs (Oils containing polychlorinated biphenyl)

Mercury

CUSTOM

7-ELEVEN TOWER CABINETS
FREESTANDING/REFRIGERATED

Table of Contents

WARNINGS	3
Operational Safety.....	3
Water.....	3
Caution.....	3
Mains Supply Cord.....	3
Specialist Disposal.....	3
Hazardous Substances.....	3
INTRODUCTION	8
Welcome	8
Future Products Group (FPG).....	8
Guidance and Help.....	8
Warranty	8
Warranty Period.....	8
Liability Exceptions.....	9
Specific Exclusions.....	9
Assessment.....	9
Time Limit.....	9
Caution.....	9
OPERATION	10
Cabinet Layout	10
Tower Series Cabinets.....	10
Lighting.....	10
Condenser Units.....	10
Thermometer.....	10
Controls	11
Power, Lights and Refrigeration Controller.....	11
Keyboard Lock.....	11
Switch Power and Lights.....	11
Preparation	12
Shelf Location and Ticketing.....	12
Shelf Adjustment.....	12
Power Supply.....	12
Refrigeration.....	12
Defrost Cycle.....	12
Routines	13
After Hours.....	13
Cleaning.....	13
Door Opening.....	13
De-frost Cycle.....	13
Temperature Checks.....	13

TROUBLE SHOOTING	14
CLEANING	15
Cautions	15
Power	15
Water	15
Exterior	15
Metal Surfaces.....	15
Painted Surfaces	15
Glass	15
Doors	15
Louvers.....	15
Front Bins	15
Interior of Refrigerated Cabinet	16
Cooling Fins.....	16
Temperature Probes.....	17
Condensate Container	17
Trays, Shelves & Air Grills.....	17
Re-assembly.....	17
Cleaning Routines	18
Schedules	18
Warning	18
Controlled Ambient Condenser Radiator.....	18
Inspection	18
Fault Correction	18
INSTALLATION	19
Regulations	19
Compliance with Local Requirements	19
Setting Up.....	19
Unpacking.....	19
Site Preparation.....	19
Cabinet Preparation.....	19
Shelf Trays	19
Grounding.....	20
Isolation	20
Location.....	20
Ventilation.....	20
Access	20
Fumes and Odours.....	20

CUSTOM

7-ELEVEN TOWER CABINETS
FREESTANDING/REFRIGERATED

SERVICING	21
Control Gear	21
Location	21
Lighting	21
Access to LED Strips	21
LED Strip Replacement	21
Refrigeration	22
Caution	22
Temperature Probes	22
Condenser Temperature Probe	22
Condenser Radiator	22
Condensate Disposal	23
Ventilation Panels	23
Cabinet Air Circulation Fans	23
Fan Replacement	23
Temperature Regulator Embraco Sync	24
Parameter Settings	24
Operation	24
Embraco Sync Connections	25
SPECIFICATIONS	26
Mechanical	26
Electrical	26
Cabinet Performance	27
Refrigeration Performance	27
Controller Settings	27
Set-Point	27
Compliance	27
Standards	27
Improvements	27
Ongoing Development	27
ELECTRICAL CIRCUIT DIAGRAMS	28
Model: IL-7EL-AT-B1xx-00	28
SPARE PARTS	29
Cabinet Serial Number	29
MECHANICAL DRAWINGS	30
Model: IL-7EL-AT-B101-00	30
.....	30
Model: IL-7EL-AT-B100-00	31
.....	31



APPENDIX A R-290 REFRIGERANT	32
General Guidance	32
R-290	32
Servicing	32
Specialized Training	32
Environment	32
Gas Detector	32
Replacement Parts	32
Fault Diagnosis	32
Check List	32
Servicing	33
Gas Monitor	33
Ignition	33
Danger Sign	33
Fire Extinguisher	33
Access Fittings	33
Electrical Connectors	33
Replacement Components	33
Tools	34
Basic Tools	34
Required Tools	34
Leak Checking	35
Warning	35
Detection Methods	35
Accessing the Refrigeration System	35
Installing Piercing Valves	35
Procedure	35
Recovering Refrigerant	36
Recovery Machines	36
Procedure Without Machine	36
Venting R-290	37
Venting Procedures	37
System Evacuation	37
Preliminary Tasks	37
NOTE	37
Evacuation Procedure	38
Charging the System	38
WARNING	38
Precautions	38
Removal and Sealing of Access Ports	39
CAUTION	39
Procedure	39
Electrical Repairs	39
CAUTION	39
Guidelines	39
Check General Condition	40
R-290 SERVICING FLOW CHART	41
REVISION HISTORY	43

CUSTOM

7-ELEVEN TOWER CABINETS
FREESTANDING/REFRIGERATED

INTRODUCTION

Welcome

TOWER SERIES CABINETS - INTRODUCTION

Future Products Group (FPG)

Welcome to the world of FPG! Our products are designed and engineered to give you the optimal performance that you deserve with innovative visual merchandising appeal.

We are confident that you will be delighted with your state of the art IMPULSE food service cabinet, and that it will become a valued appliance in your store.

Guidance and Help

Any new appliance can seem very complex and confusing at first glance. To ensure you receive the utmost benefit from your new IMPULSE cabinet, there are two things you can do.

- Before operating the cabinet, please read the instruction book carefully and follow its recommendations. The time taken will be well spent. These instructions both general and technical tell you how to operate and look after your IMPULSE food service cabinet so that you can receive the full benefits that this cabinet has to offer.
 - These instructions cannot, however, cover all eventualities. If you are unsure of any aspect of the installation, instructions or performance of your cabinet, contact your dealer promptly or contact us via email to support@fpgworld.com.
-

Warranty

TOWER SERIES CABINETS - INTRODUCTION

Warranty Period

Future Products Group Limited warrants, to the original purchaser of an FPG manufactured food service cabinet, that for TWO YEARS (24 months) from the date of purchase, any defect in workmanship or material resulting in the product malfunctioning while under correct use will be rectified.

For refrigerated cabinets with integral or near-remote refrigeration the warranty is extended to THREE YEARS (36 months), for refrigeration condenser units. Conditions apply, see Liability Exceptions.

Liability under this warranty is limited to replacing or repairing a part, without charge.

Continued on next page

Warranty cont.

TOWER SERIES CABINETS - INTRODUCTION

Liability Exceptions

Liability under this warranty does not include:

- Any loss, damage, or expenses directly or indirectly arising from the use of, or inability to use, the product or from any other cause.
 - Any part of the cabinet which has been subject to misuse, neglect, alteration, incorrect installation, accident, or damage caused by transportation, use of abrasive or caustic chemicals, flood, fire or acts of God.
 - Damage, resulting from failure to have the cabinet regularly serviced by a refrigeration engineer:
 - For cabinets with integral or near-remote refrigeration, every three months. NB: You will be required to provide copies of service records in the event of condenser failure.
 - For cabinets with remote refrigeration, annually.
 - Any damage or malfunction, resulting from the use of non-FPG supplied spare parts.
-

Specific Exclusions

The following are specifically excluded from warranty:

- Breakage of glass or plastic components, or the replacement of LED lighting assemblies or gaskets.
 - Maladjustment of the electronic refrigeration controller, by an unqualified person.
 - For cabinets with integral or near-remote refrigeration, failure resulting from a lack of routine condenser / radiator cleaning.
 - Failure to re-assemble the cabinet correctly after cleaning.
 - Fair wear and tear.
-

Assessment

The liability under this warranty is dependent on an assessment by FPG, to determine the defect in workmanship or materials.

Time Limit

FPG does not guarantee that any service to be performed under this warranty will be carried out within any particular time limit.

Caution

FPG will not be held responsible for any servicing costs incurred prior to FPG's acceptance of a warranty claim.

CUSTOM

7-ELEVEN TOWER CABINETS
FREESTANDING/REFRIGERATED

OPERATION

Cabinet Layout

TOWER SERIES CABINETS - OPERATION

Tower Series Cabinets



The Tower Series cabinets have hinged glass front doors, and closed backs.

The series includes Controlled Ambient and Heated models.

The controlled ambient cabinets are supplied with integral refrigeration condensers and automatic condensate removal ACR units.

The controller for cabinet lighting and refrigeration is accessible by lifting the flap, at the top of the cabinet.

Bins are available for bags etc.



Lighting

All cabinets are fitted with high efficiency LED lights as standard.

Condenser Units

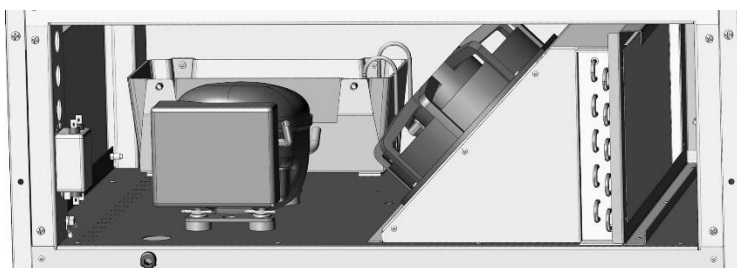

The VSD condenser unit, fans and ACR are located in the base of the cabinet.

The cabinet has openings to allow adequate ventilation to ensure efficient

refrigeration performance.

Articles which could restrict air flow must NOT be placed against the cabinet.

Thermometer



Cabinets have a thermometer under the top pelmet, on the right hand side.

This indicates the internal temperature of the cabinet.

Controls

TOWER SERIES CABINETS - OPERATION

Power, Lights and Refrigeration Controller

The refrigeration controller features a touch-screen display.

The controller regulates the cabinet temperature and controls the automatic defrost cycles.



Keyboard Lock

The keyboard is normally locked to prevent accidental parameter changes.

To activate/deactivate the keyboard lock, simply touch all four keys at the same time until the display shows “Loc”/“UnL”, respectively.

When a key is touched with the keyboard locked, the display shows “Loc”.

The keyboard is automatically locked after 60s of inactivity.



Switch Power and Lights

It is necessary to unlock the keyboard in order to switch on the cabinet or the lights. See above paragraph.



The temperature controller is pre-set to maintain the cabinet temperature between 2°C and 4°C. It should not need adjustment.

Press the power button for 5s to toggle the cabinet ON OFF.

Press the light button until “Lit” displayed then for 1s to toggle the lights ON and OFF.

CUSTOM

7-ELEVEN TOWER CABINETS
FREESTANDING/REFRIGERATED

Preparation

TOWER SERIES CABINETS - OPERATION

Shelf Location and Ticketing

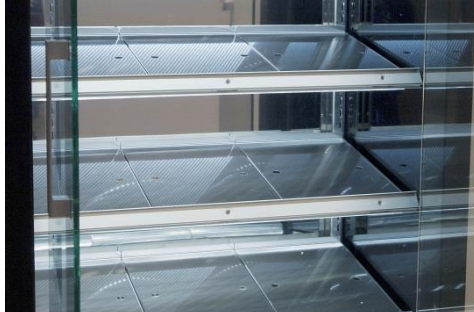

All shelves are adjustable in height and can easily be moved up or down, to match product size.

The permitted movement is restricted to 50mm, because of the electric cables to the lights and air flow considerations.

The front edges of the shelves are profiled to carry ticketing/labels.

Shelf Adjustment



Using two people, one on each bracket, lift the brackets straight up firmly and then pull the brackets forward, to disengage them from the slots in the support posts.

Insert the brackets into their new position, and push bracket down firmly.

N.B. Make sure brackets are pushed down as far as they can go. Failure to do this may result in shelf collapse, when loaded with product.

Power Supply

Confirm that the local mains supply conforms to that shown on the cabinet serial number label. Connect the power supply lead to a mains socket.

Refrigeration

On controlled ambient cabinets, the compressor will run as soon as the cabinet main switch is turned on, and the cabinet temperature will be controlled.

The temperature controller is pre-set to maintain the cabinet temperature at 18°C, and should not need adjustment.

Defrost Cycle

Note that the defrost times are set from when the cabinet is first turned on. If they are required at a particular time, you must turn on the cabinet four hours before the first defrost required. The cycles will then occur every four hours, provided that the cabinet is not switched off.

Each defrost cycle terminates as soon as the temperature of the evaporator fins rises to a level indicating that all ice has melted. This active control improves the energy efficiency of the cabinet, and minimises temperature fluctuations.

Do NOT check the cabinet temperature within ½ hour of a de-frost cycle.

Continued on next page

Routines

TOWER SERIES CABINETS - OPERATION

- After Hours** If controlled ambient cabinets are not turned off after hours or at night, shut the doors and turn off the lights. The cabinet will then operate on minimum load, and be ready for instant operation when next required.
- If cabinets are turned off, to conserve energy, products must be removed and stored at an appropriate temperature.
- When turned on again, allow cabinets to run for about half an hour before replacing the products.
-
- Cleaning** Since cabinets need to be switched off during cleaning operations, it is best to clean them at the end of the working day. Cabinets will then have time to recover their normal operating temperature, before replacing the products for the next day's business.
-
- Door Opening** The cabinets are designed to maintain food at the correct temperature with the doors being opened and closed up to 75 times per hour. If the doors are left open for an extended period the temperature will deviate. Once the doors are shut the temperature will take some time to return to the normal operating level. The longer the doors are open the longer the time to restore normal operating temperature.
-
- De-frost Cycle** Defrosting of the evaporator coil is fully automatic, taking place every two hours.
- If you suspect that the defrost system is not working properly, have it checked by a qualified service person.
- Operators must not attempt to adjust the refrigeration controller.**
-
- Temperature Checks** Cabinet temperatures should be routinely checked, to confirm satisfactory operation.
- The refrigeration controller shows the temperature of the circulating air, as it enters the cooling coil. This will be slightly higher than the air temperature in the display area, so a temperature probe should be used to check product temperatures.
- To avoid misleading temperature measurements, do not take a reading within 20 minutes of a defrost cycle.
-

CUSTOM

7-ELEVEN TOWER CABINETS
FREESTANDING/REFRIGERATED

TROUBLE SHOOTING

FAULT	POSSIBLE CAUSE	REMEDY
Cabinet does not operate/start	The mains isolating switch on the wall, circuit breaker or fuses are off at the power board	Turn isolating switch circuit breaker or fuses on
	The power switch on the controller is OFF	Press the power button
	The internal fuse has blown	<i>Have circuit checked and replace fuse</i>
	The controller is faulty	<i>Have the controller replaced</i>
A03 Alarm Display on Controller	Compressor discharge pipe high temperature	<i>Call for service, to investigate problem</i>
A07 Alarm Display on Controller	Faulty temperature probe	<i>Call for service, to investigate problem</i>
Refrigerated Cabinet does not reach temperature	Ventilation grills are blocked	Vacuum or remove blockage
	Product blocking air grill	Place product on shelves
	Thermostat needs adjustment	<i>Adjust refrigeration controller</i>
	Ambient > 25°C & 60%RH	Adjust store air conditioning
	Evaporator coil iced up	<i>De-ice coil, check defrost parameters, replace controller if found faulty</i>
	Condenser radiator blocked	<i>Remove dust and debris</i>
	Refrigeration controller faulty	<i>Replace controller</i>
	Temperature probe damaged	<i>Replace temperature probe</i>
	Fans not operating	<i>Have fans checked/replaced</i>
Condensate Overflows	Defrost cycle unsuitable	<i>Have defrost cycle adjusted</i>
Cabinet lights not working	LED strip has failed	<i>Replace LED strip</i>
	LED power supply has failed	<i>Replace LED power supply</i>
	Internal fuse has blown	<i>Have circuit checked and replace fuse</i>
Aluminium parts corroded	Caustic detergent damage	Order replacement parts

Service Personnel Only

The table entries in ***italics*** indicate actions to be taken only by qualified Service Personnel.

CLEANING

Cautions

TOWER SERIES CABINETS - CLEANING

Power **ALWAYS SWITCH THE ELECTRICITY SUPPLY OFF BEFORE CLEANING.**

Water **CABINETS ARE NOT WATERPROOF. DO NOT USE A WATER JET SPRAY TO CLEAN THE INTERIOR OR EXTERIOR OF CABINETS.**

Exterior

TOWER SERIES CABINETS - CLEANING

Metal Surfaces Stainless steel or aluminium surfaces should be cleaned with hot soapy water or a good quality metal cleaning compound. **DO NOT** clean surfaces with abrasive pads or cleaners, as stainless steel and aluminium surfaces will be damaged.

Painted Surfaces Painted surfaces should be cleaned with hot soapy water. Do not use abrasives or strong solvents, because they will damage the surface.

Glass All glass should be cleaned using a good quality glass cleaner and a clean cloth.
DO NOT use abrasive pads or cleaners, because they will damage the surface of the glass.

Doors The hinged cabinet doors are not readily removable, and should therefore be cleaned in place.

Louvers Use a vacuum cleaner to remove dust and fluff from all ventilation apertures. This will prevent overheating, and maintain the refrigeration efficiency of controlled ambient cabinets.

Front Bins



The front bins can be removed from the cabinets, for ease of cleaning.

Simply lift the bin insert vertically from the cabinet.

CUSTOM

7-ELEVEN TOWER CABINETS
FREESTANDING/REFRIGERATED

Interior

TOWER SERIES CABINETS - CLEANING

Interior of Refrigerated Cabinet

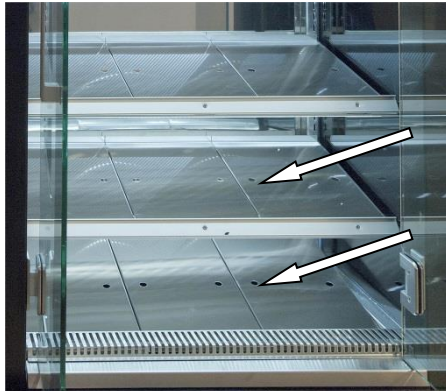

Using the finger holes, remove the shelf trays and deck trays.

The inside of the cabinet can be cleaned without removing the shelf support brackets.

Clean all brackets and ticketing rails.



Remove the air louvers.

Sweep out, or use a vacuum cleaner, to remove any debris from the cabinet base cavity. Check the drain hole is clean.

A Wet-and-Dry vacuum cleaner should be used, since there is likely to be some water in the bottom. Finally, wipe out the bottom with a damp sanitized cloth.

Do not pour water into the base, or the condensate container will overflow.



To access the cooling coil for extra cleaning. Remove the two screws, securing the fan deck.

Lift the cover plate off the evaporator coil and disengage it from the chassis.

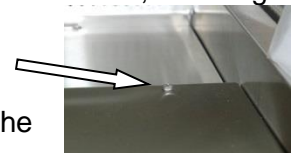

Cooling Fins

If there is food stuck in the cooling fins, it is best to use a wet and dry vacuum cleaner to suck out the food. DO NOT attempt to hose food parts from fins.

Caution: The fins are very sharp. Take extra care when cleaning this area. Do not bend the fins over, as this would restrict the air flow and degrade cabinet performance.

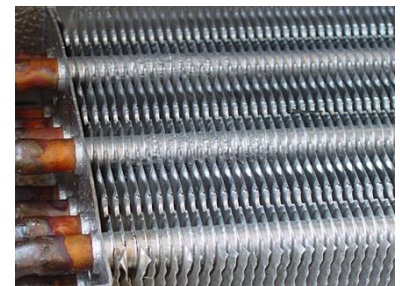

Continued on next page

Interior cont.

TOWER SERIES CABINETS - CLEANING

Temperature Probes

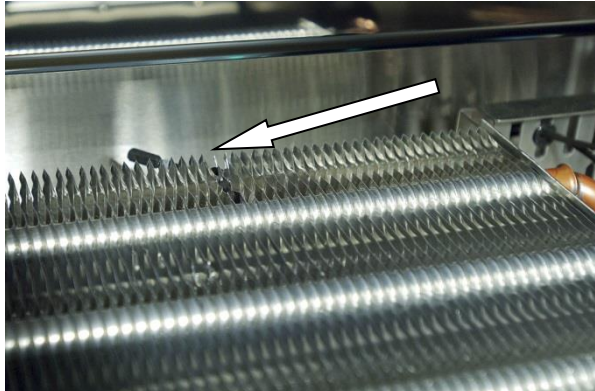

Take care not to damage or move the temperature probes, when cleaning the cooling fins.

The probes are located towards the back of the cabinet, so are not easily accessed.

One probe is inserted between the fins of the cooling coil and the other is in free air.

Condensate Container

The condensate container is only designed to handle cooling-coil defrosting liquid that drains from the well.

DO NOT fill the well with liquid, or attempt to hose out as condensate container will overflow and leak onto floor.

Trays, Shelves & Air Grills

Stainless steel trays, shelves, grills etc. should be cleaned with hot soapy water. Do not use abrasive pads or cleaners, as these may damage surfaces.

Warning: Dishwasher detergents will damage any anodised aluminium parts.

Re-assembly

Take care to re-assemble panels and covers correctly, as any air gaps can adversely affect air circulation and the cabinet temperature.

CUSTOM

7-ELEVEN TOWER CABINETS
FREESTANDING/REFRIGERATED

Cleaning Routines

TOWER SERIES CABINETS - CLEANING

Schedules To maintain optimum performance, cleaning schedules must be regular and thorough.

Warning **Failure to carry out routine cleaning/servicing schedules will void the warranty on refrigeration equipment.**

Controlled Ambient Condenser Radiator

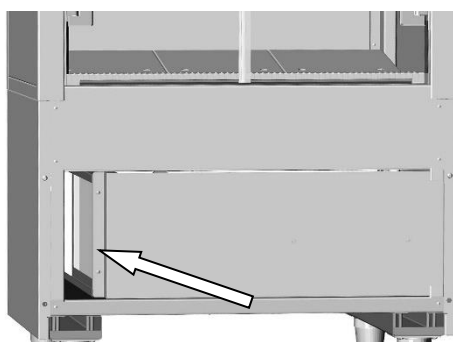

For efficient refrigeration performance, the condenser radiator must be kept clean. Failure to do this will lead to a build up of dust, and restricted airflow will prevent the unit from working properly. The compressor may overheat and the cabinet temperature may rise.

The condenser radiator can be accessed from the front of the cabinet, after removing the front bin. Simply lift the bin insert

vertically to remove it from the cabinet.

Be very careful not to bend or damage the soft aluminium fins when vacuuming the radiator. If the fins are flattened, airflow will be restricted and overheating will result.

Regular vacuuming will prevent a build-up of dust and fluff, however, three monthly service checks by a refrigeration engineer, which include cleaning the condenser with compressed air, are mandatory.

Inspection As part of the cleaning routine, the controls, mechanical parts and electrical wiring should be inspected for damage, deterioration or need of adjustment.

Fault Correction If any small faults are found, have them attended to promptly by a competent serviceman. Don't wait until they cause a complete breakdown.

INSTALLATION

Regulations

TOWER SERIES CABINETS - INSTALLATION

Compliance with Local Requirements

It is very important that your inline food cabinet is installed correctly and that the operation is correct before use. Installation must comply with local electrical, health & safety and hygiene requirements.

Setting Up

TOWER SERIES CABINETS - INSTALLATION

Unpacking

Unpack and check unit for damage and report any damage to the carrier and supplier. Report any deficiencies to your supplier.

The cabinets are supplied fully assembled, with the shelf trays wrapped separately and secured inside the cabinet.

Site Preparation

Position the cabinet in its allocated working position. Use a spirit level to ensure the cabinet is level from side to side and front to back. (If this is not carried out, water may accumulate in the cabinet well of refrigerated cabinets, and uneven temperature distribution could also occur).

Cabinet Preparation

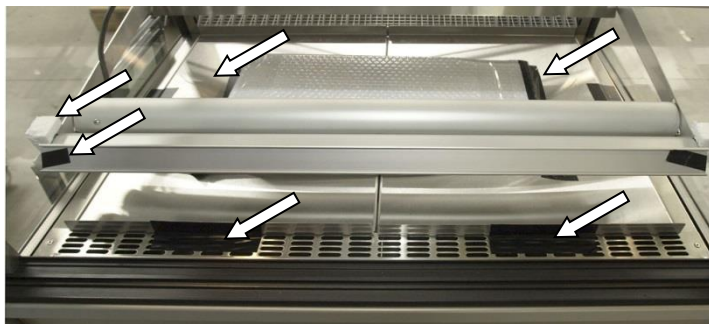

Remove all protective plastic film, tapes, ties and packers, used to prevent movement during transit.

Lift out the deck trays to gain access to the cabinet well. Be sure to replace them correctly.

Shelf Trays

Remove the shelf trays from their packing, peel off any protective plastic coating and assemble them on the support members.

Continued on next page

CUSTOM

7-ELEVEN TOWER CABINETS
REFRIGERATED

Setting Up cont.

TOWER SERIES CABINETS - INSTALLATION

Grounding

WARNING: THIS APPLIANCE MUST BE GROUNDED TO EARTH

The earth lead, in the mains cable, must always be connected to ground.

The earth terminal can also be used to bond the cabinet to a surge grounding conductor or to adjacent equipment.

The incoming phase and neutral leads are connected directly to the EMI line filter, which is located just above the cabinet base.

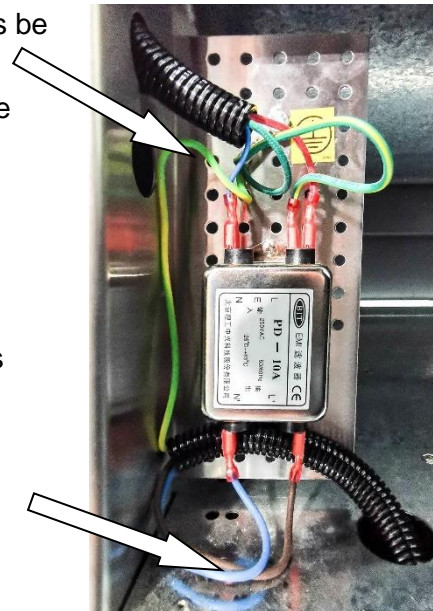

Isolation

If the cabinet is not connected by a plug and socket, but is hard wired to the mains supply, a means of isolation must be provided.

If a plug and socket are used, they should still be accessible after the cabinet is installed.

Location

TOWER SERIES CABINETS - INSTALLATION

Ventilation

Ventilation openings on refrigerated cabinets must never be obstructed. If obstructed the condenser may overheat and cause an electrical malfunction.

The heated cabinet is designed to meet the HACCP specification with free room air circulation.

Access

The cabinet should be positioned so the operating controls are accessible. The shelves must also be easily reached, for loading and unloading.

Fumes and Odours

Before use, operate heated cabinets for 4 hours, to remove any fumes or odours, which may be present. Open the doors periodically during this period, to allow a change of air. This will avoid possible tainting of food.

SERVICING

Control Gear

TOWER SERIES CABINETS - SERVICING

Location The electrical control gear for the Controlled Ambient cabinet is located in the top of the cabinet, and is reached by removing an access panel.
Here will be found a mains fuse and the power supplies for the LED lights.

Lighting

TOWER SERIES CABINETS - SERVICING

Access to LED Strips The LED strips are protected with plastic covers. These clip into grooves in the aluminium extrusion.
Remove the plastic cover to access the LED strip.

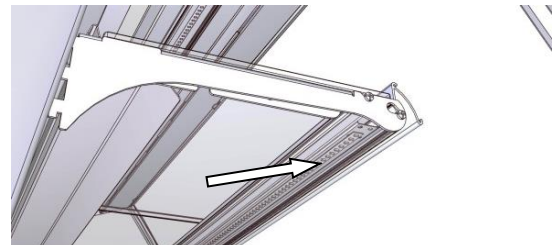

LED Strip Replacement | With the power off, cut the connecting cable close to the LED strip.
Pull off the faulty strip and replace it with the new self-adhesive one.
Splice the connecting cables together with the supplied insulated crimp connectors, making sure to maintain the correct polarity.
Replace the plastic cover.



Continued on next page

CUSTOM

7-ELEVEN TOWER CABINETS
REFRIGERATED

Refrigeration

TOWER SERIES CABINETS - SERVICING

Caution

DO NOT attempt to service the refrigeration equipment without isolating the cabinet at the supply switch or by unplugging it from the supply.

Temperature Probes



There are two temperature probes on the cooling coil.

One probe is inserted between the fins and controls the defrost cycle.

The other is in free air, and controls the cabinet temperature.

A third probe is mounted on the condenser discharge pipe.

Condenser Temperature Probe



A temperature probe, connected to the XR40CX refrigeration controller, is mounted on the discharge pipe of the condenser unit, to guard against overheating.

If the set temperature is exceeded, the refrigeration will be shut down to avoid damage.

Condenser Radiator

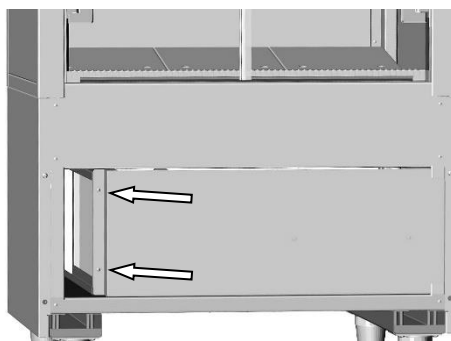

Remove the access panels from the front and back of the cabinet to reach the condenser unit.

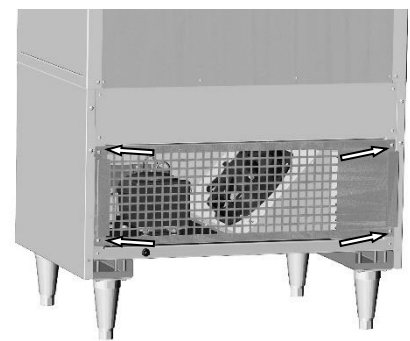

For efficient refrigeration performance, the condenser radiator must be kept clean.

Regular vacuuming will prevent a build up of dust and fluff, however, three monthly service checks by a refrigeration engineer, which include cleaning the condenser with compressed air, are mandatory.

Be very careful not to bend or damage the soft aluminium fins when vacuuming the radiator. If the fins are flattened, airflow will be restricted and overheating will result.

Continued on next page

Refrigeration cont.

TOWER SERIES CABINETS - SERVICING

Condensate Disposal

The automatic condensate removal, ACR system consists of a water tray with an evaporation coil.

The evaporation coil is inserted in the hot gas flow of the refrigeration compressor, and heats any condensate whenever the compressor is running. It is normal for water to be present immediately following a defrost cycle.

Ventilation Panels

All ventilation panels should be kept free of dust by regular vacuuming, so that air flow is not restricted.

Cabinet Air Circulation Fans



The cabinet air circulation fan is located in the base of the cabinet.

Access is gained by removing the deck trays.

Remove two screws, at the left and right rear of the fan deck, to allow it to be lifted upwards.

Fan Replacement



The fans is hard-wired, so the lead must be cut and re-spliced to the replacement fan.

The joint must be adequately protected, using heat shrink sleeves, to prevent ingress of moisture.

Continued on next page

CUSTOM

7-ELEVEN TOWER CABINETS
REFRIGERATED

Refrigeration cont.

TOWER SERIES CABINETS - SERVICING

Temperature Regulator Embraco Sync



The Embraco Sync is a microprocessor-based controller, featuring a touch-screen.

It is provided with three NTC probes. The first one for temperature control (air on), the second one, located on the evaporator coil, to control the defrost termination, the third one senses the temperature of the compressor discharge pipe.

The set-point temperature will be higher than the air temperature inside the cabinet, because the refrigeration compressor is controlled in response to the incoming air (air on) temperature entering the evaporator cooling coils.

The instrument controls the speed of the VSD inverter/compressor to maintain the set cabinet temperature.

The instrument features a touch-screen display, and is fully configurable through special parameters that can be easily programmed through the keyboard.

A special cable is used to connect the controller to the variable frequency inverter, which drives the variable speed compressor.

Parameter Settings

The Embraco controller has a multitude of parameter settings, which enable the cabinet performance to be optimized for performance and efficiency.

The settings are factory set after extensive testing, and can only be altered after entering a password. Contact FPG for further information.

Operation

Only four functions are available to the operator for every-day use, Cabinet ON/OFF, Lights ON/OFF, Set-Point adjust and Manual Defrost.

ON/OFF Press for 5s, to turn ON/OFF

LIGHTS Press until "Lit" displayed, then 1s press toggles lights ON/OFF

SETPOINT Press until "Set" shows, use UP (defrost) and DOWN (power) buttons to adjust

DEFROST Press until "DFr" shows

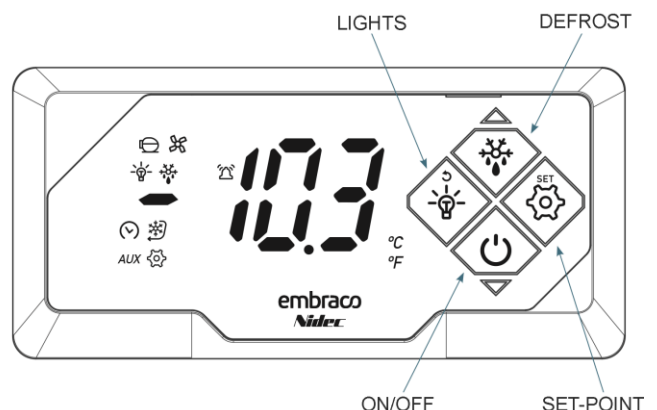

Continued on next page

Refrigeration cont.

TOWER SERIES CABINETS - SERVICING

Embraco Sync Connections

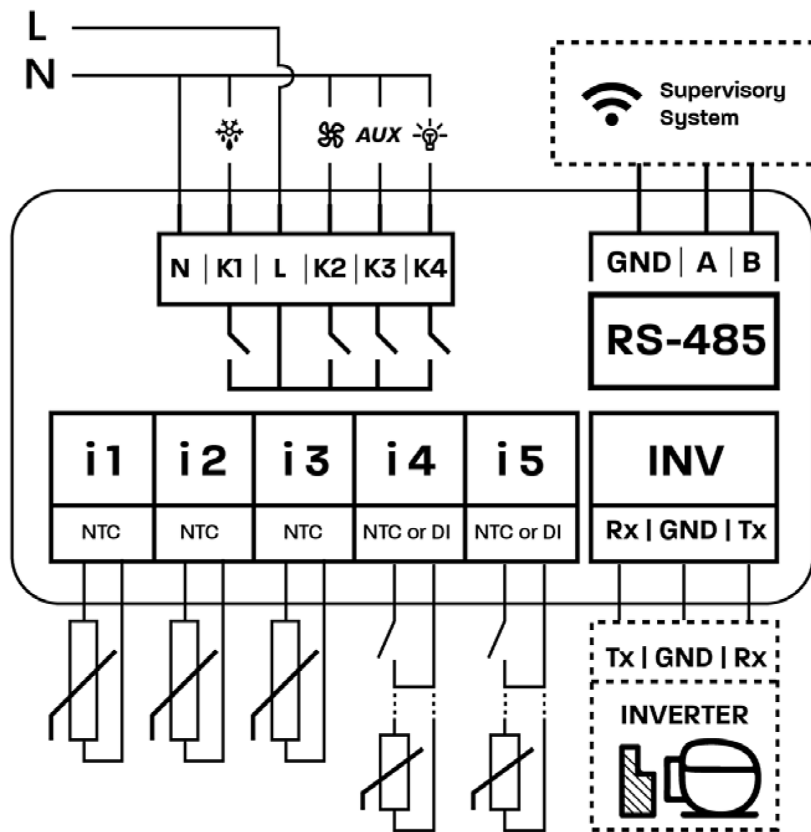
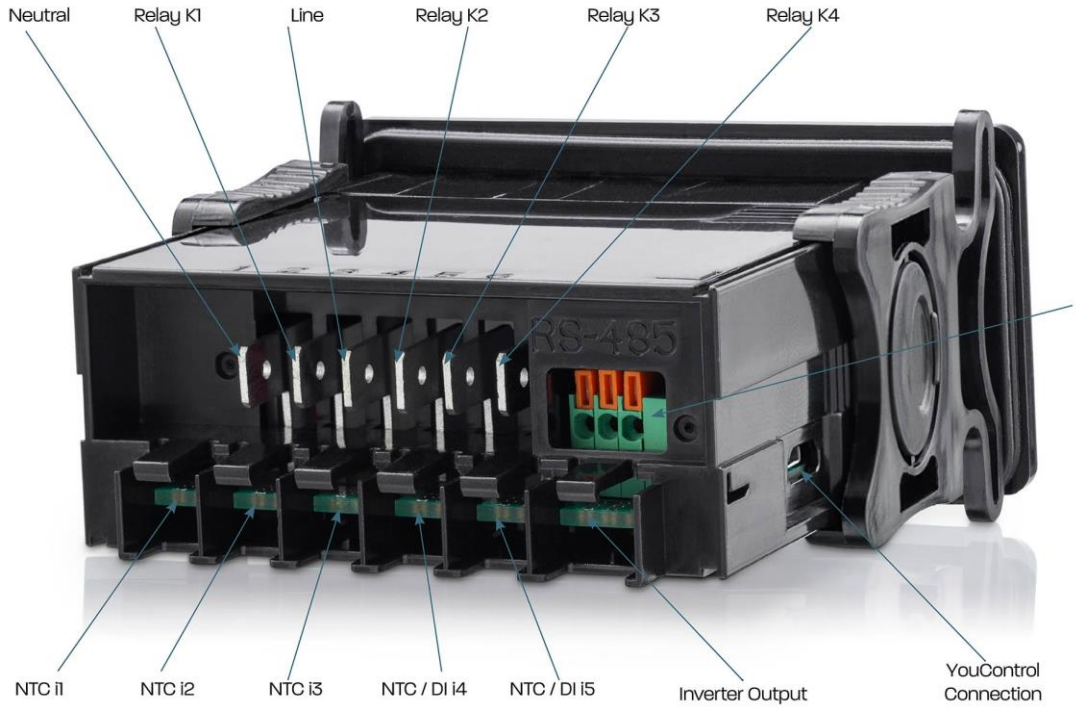

CUSTOM

7-ELEVEN TOWER CABINETS
REFRIGERATED

SPECIFICATIONS

Mechanical

TOWER SERIES CABINETS - SPECIFICATIONS

	CABINET MODEL
	IL-7EL-AT-B1xx-00
Height mm	2060
Width mm	800
Depth mm	773 / 643
Dry Weight	190kg
Cabinet Well Material	Stainless steel
Number of Shelves	7
Display Area m ²	1.1
Refrigerant	R-290
Refrigerant Charge	Refer to cabinet Serial No./Rating label
Condensate capacity	3 litres
Climatic Class & IP Rating	All cabinets are suitable for class N climates and have an IP 22 rating

Electrical

TOWER SERIES CABINETS - SPECIFICATIONS

	CABINET MODEL
	IL-7EL-AT-B1xx-00
Voltage	220-240 V 50/60 Hz 1 ϕ
Max Power	354W
Energy Consumption	0.144kWh/h
Max Current	1.54A
Connection	3 core cable with 10A plug
Temperature Range, °C	16 - 18°C
Lights	Top and base lights plus one per shelf

Cabinet Performance

TOWER SERIES CABINETS - SPECIFICATIONS

Refrigeration Performance	Operating Temperature	Average Internal Humidity	Climatic Class 3 Test Conditions
	+16° to +18°C	N/A	25°C Ambient with 60% RH

Controller Settings

TOWER SERIES CABINETS - SPECIFICATIONS

Set-Point The factory setting for set-point is **16°C**.
 All other parameter settings are password protected, and can only be altered in consultation with FPG.

Compliance

TOWER SERIES CABINETS - SPECIFICATIONS

Standards FPG refrigerated, controlled ambient and ambient food display cabinets are designed to meet and exceed:

- International safety standards for electrical appliances: IEC 60335-1, IEC 60335-2-89, and the equivalent country-specific standards including AS/NZS, BS EN and UL 471.
- International standards for electromagnetic compatibility/emissions: CISPR 14-1, and the equivalent county-specific standards including AS/NZS CISPR and BS EN 55014-1.
- Essential safety requirements: AS/NZS 3820 and AS/NZS 4417
- Energy efficiency for refrigerated appliances: MEPS (Australia/New Zealand)

Please contact FPG to discuss your requirements for meeting country-specific standards.

Improvements

TOWER SERIES CABINETS - SPECIFICATIONS

Ongoing Development FPG reserves the right to change specifications and construction, as part of ongoing product improvement.

CUSTOM

7-ELEVEN TOWER CABINETS
REFRIGERATED

ELECTRICAL CIRCUIT DIAGRAMS

Model: IL-7EL-AT-B1xx-00

Tower Series, 800mm Controlled Ambient Cabinet

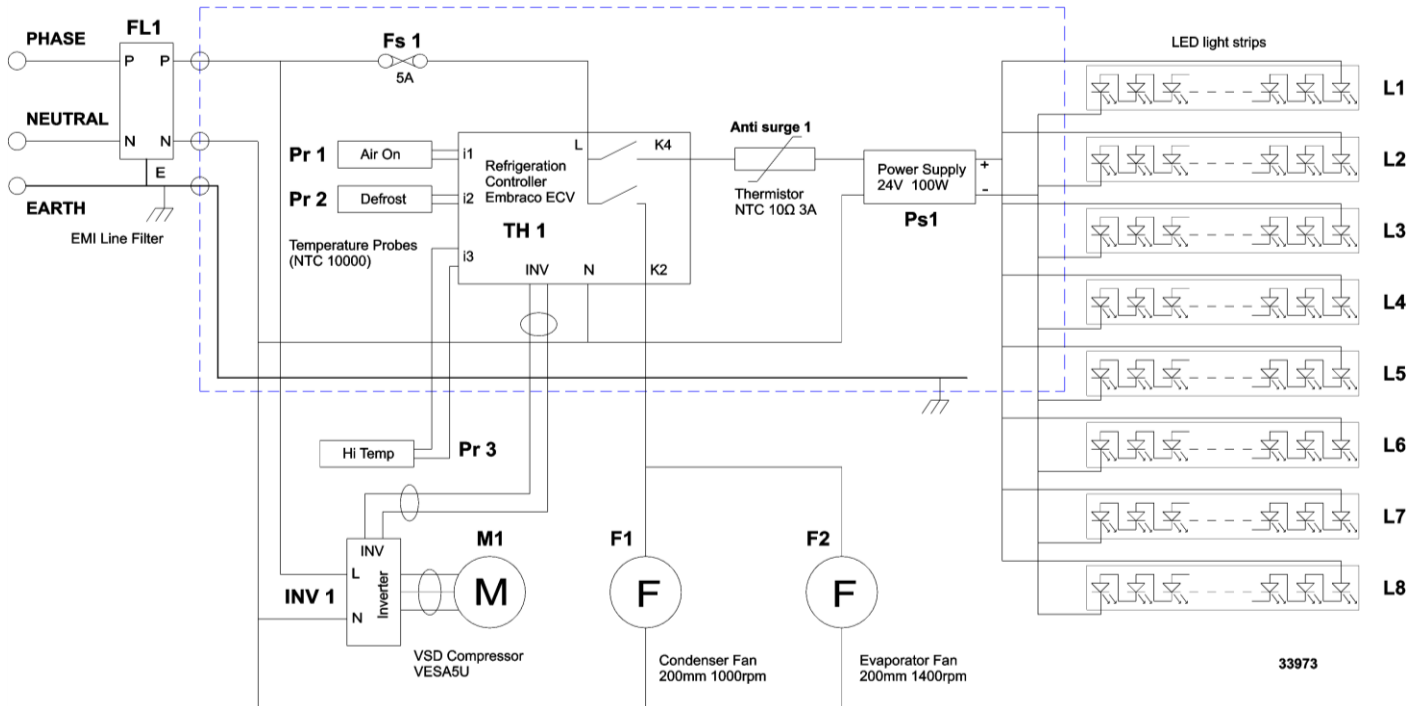

SPARE PARTS

Cabinet Serial Number

When ordering spare parts, it is important to quote the Serial Number printed on the label fixed to the control panel.

This serial number will enable FPG to trace details of the build specification of your particular cabinet, and hence ensure that spare parts are fully compatible.

To satisfy warranty conditions, and ensure optimum performance, use only FPG supplied spare parts.

Part Description	FPG Part No.
Barrel thermometer	11924
Embraco Refrigeration Controller <i>pre-programmed</i>	79179
NTC temperature probe (Black, Defrost)	79029
NTC temperature probe (Red, Hi Temp)	79031
NTC temperature probe (Green, Air On)	79028
Condenser Fan 200mm 1000rpm	78273
Evaporator Fan 200mm 1400rpm	79198
Embraco VEHT409U VSD compressor and inverter	33450
Fuse Link (5A, 250V, Slow Blow)	13330
Polycarbonate Light Cover Top Light	32472
Polycarbonate Light Cover 720mm Shelf Light	29404
24V 100W LED power supply	30086
Anti-surge thermistor 10 Ohm 3A	22354
Top/Shelf Light Replacement Kit, Ref/Amb	69492
Left front door	65824
Right front door	65824
Magnetic door-catch keeper plate	13383
Door handle	30512
Door hinge	29516
10mm plastic fin seal for 8mm glass doors 1270mm long	24396
Replacement door glass	22486
Product Manual for IL-7EL-AT-B1xx-00	33972

CUSTOM

7-ELEVEN TOWER CABINETS
REFRIGERATED

MECHANICAL DRAWINGS

Model: IL-7EL-AT-B101-00

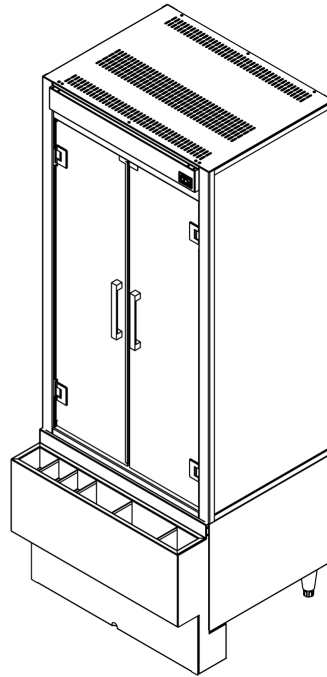
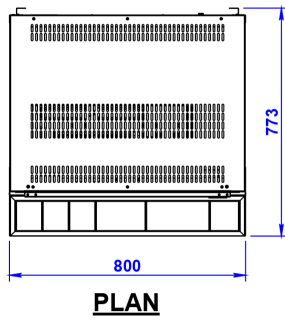

PERSPECTIVE

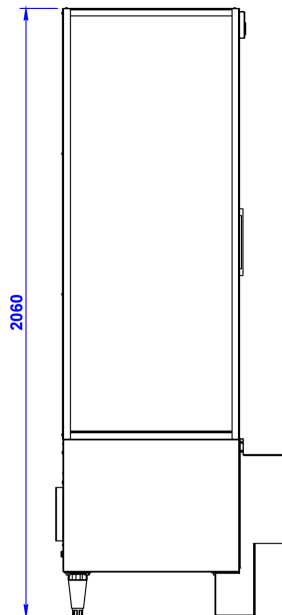
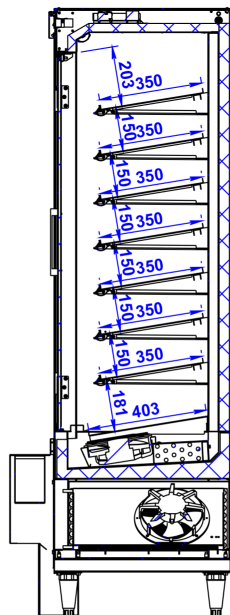
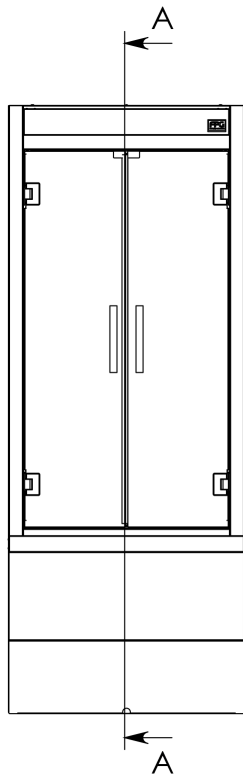

Model: IL-7EL-AT-B100-00

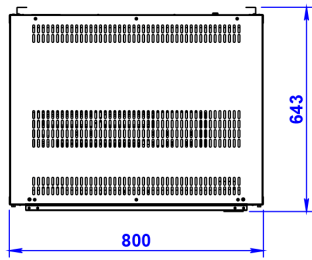

PLAN

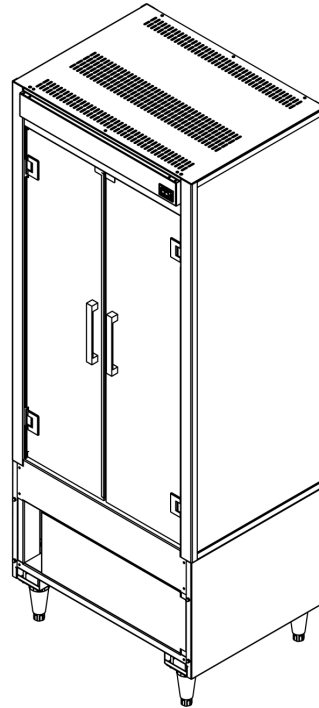

PERSPECTIVE

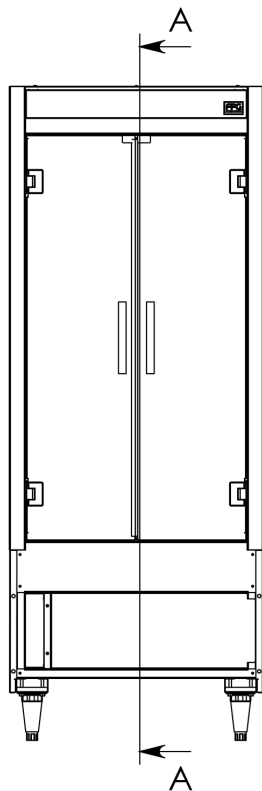

FRONT ELEVATION

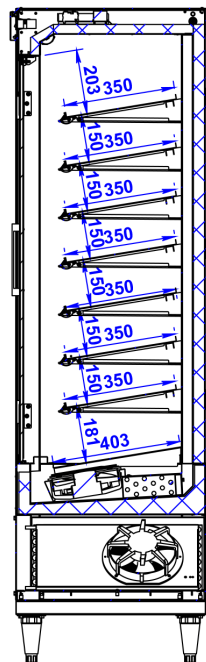

SECTION A-A

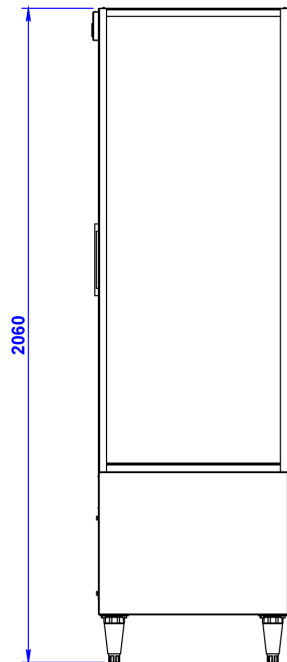

SIDE ELEVATION

CUSTOM

7-ELEVEN TOWER CABINETS
REFRIGERATED

APPENDIX A R-290 Refrigerant

General Guidance

TOWER SERIES CABINETS - APPENDIX A
R-290 Refrigerant

R-290 R-290 is the name for refrigerant grade high purity odorless propane.
It is NOT barbeque grill propane.
PROPANE IS HIGHLY FLAMMABLE. You MUST observe caution and proper safety practices when servicing equipment with R-290.



Servicing Servicing refers to making repairs to the hermetically-sealed system and any parts of the electrical system.

Specialized Training Although not mandatory, specialized training of service personnel is desirable.

Environment Repair on R-290 equipment should always be done in a well ventilated area.

Gas Detector Because R-290 is highly flammable, an electronic combustible gas leak detector is required when servicing R-290 systems.

Replacement Parts When opening any refrigeration system, the filter/dryer must be replaced with the manufacturers specified spare part.

Fault Diagnosis Since there are no access fittings on R-290 systems, temperatures and current draw must be used to evaluate system performance.

Check List Before proceeding with servicing, check the following:

MONITOR: make sure the combustible-gas meter is on and in proper position.
VENTILATE: make sure there is adequate ventilation in the work area.
ELIMINATE: make sure to eliminate any potential ignition sources.

Servicing

TOWER SERIES CABINETS - APPENDIX A
R-290 Refrigerant

Gas Monitor Before entering any service area that may have hydrocarbons, always turn on a combustible gas monitor to alert you to the presence of flammable refrigerants while you are working.

Do not turn the combustible gas monitor off until you leave the service area.

Ignition Do not unplug, disconnect power to, or begin servicing a system before checking for flammable refrigerants with the combustible gas monitor.

Sparks from unplugging or power disconnects could ignite flammable refrigerants.

Danger Sign Display a Danger Propane placard to alert all that you are working on a R-290 system.

No open flames or smoking is allowed.

Instruct anyone in the immediate area the nature of the work taking place.

Be aware that E-cigarettes or similar electronic devices could be a source of ignition.



Fire Extinguisher An approved fire extinguisher is required when servicing a system that contains a flammable refrigerant.

Access Fittings Since access fittings are not supplied on any R-290 systems. Before adding access-fittings you should check temperatures and amps and contact FPG for guidance on fault finding.

Electrical Connectors  Wire nuts are not approved for R-290. All connectors must be UL approved for use with Hydrocarbons.

Wire connectors must have sufficient strength to hold the conductor/wire in place.

Replacement Components When replacing components, ignition-proof sealed electrical components are required.

To avoid using unapproved parts, only FPG replacement parts are to be used on a R-290 system.

CUSTOM

7-ELEVEN TOWER CABINETS
REFRIGERATED

Tools

TOWER SERIES CABINETS - APPENDIX A
R-290 Refrigerant

Basic Tools Use the same basic refrigeration tools as for R404-A & R-134a refrigerant.

Required Tools

	<p>Combustible gas leak detector (Inficon Gas Mate) or equal</p>		<p>Propane warning notice</p>
	<p>Tubing cutter</p>		<p>Approved fire extinguisher (Class B dry powder type)</p>
	<p>Vacuum gauge</p>		<p>30cm charging hose (low Loss design)</p>
	<p>Ball charging valves (3)</p>		<p>Gram scale</p>
	<p>Tap valves 1/4" (2)</p>		<p>Digital thermometer</p>
	<p>Pinch off tool (2)</p>		<p>Venting hose</p>

Leak Checking

TOWER SERIES CABINETS - APPENDIX A
R-290 Refrigerant

Warning Do NOT use any leak test dyes when working on an R-290 refrigeration system.

Detection Methods

- Bubble test.
- Electronic combustible gas detection.
- Nitrogen holding pressure test (only possible on accessed systems).

For the most part, you would leak check a R-290 system the same way you would a R-134a or R-404A system with a couple of exceptions.

You cannot use a halide leak detector on an R-290 system, the electronic leak detector must be designed specifically for combustible gas.

Using oxygen-free dry nitrogen with a trace gas not exceeding 150PSIG is also recommended.





Accessing the Refrigeration System

TOWER SERIES CABINETS - APPENDIX A
R-290 Refrigerant

Installing Piercing Valves Line tap valves can be used to access the refrigeration system. Line tap valves should be temporarily placed on the suction and liquid process tubes.

IMPORTANT: Never leave piercing valves of any type on the R-290 refrigeration system. This would void the warranty.

Procedure

<p>Make sure the cabinet is disconnected from the power source.</p> <p>Wear safety glasses and gloves (rubber coated are best).</p>	
<p>Turn the combustible-gas leak detector "ON".</p> <p>Refer to the manufacturer's instructions for the detector you are using.</p>	
<p>Post the warning notice in plain view for all to see on the front and rear of the refrigeration appliance.</p>	
<p>Remove the red sleeves on the suction and liquid line process tubes.</p> <p>Install the piercing valves following manufacturer's instructions.</p> <p>Red sleeves must be replaced when done servicing.</p>	

CUSTOM

7-ELEVEN TOWER CABINETS
REFRIGERATED

Recovering Refrigerant

TOWER SERIES CABINETS - APPENDIX A
R-290 Refrigerant

Recovery Machines

Recovery machines for use with hydrocarbon refrigerants are in limited production.

Only an explosion proof recovery machine can be used to recover.

Procedure Without Machine

1. Evacuate an empty recovery cylinder into a vacuum.
2. Using an accurate refrigerant scale, zero out the refrigerant scale and weigh the empty recovery cylinder prior to adding refrigerant gauges or hoses. Note this weight.
3. Securely connect the evacuated cylinder to the refrigeration system using refrigerant gauges and hoses.
4. Open both refrigerant gauges to allow refrigerant to flow through the gauges to the recovery cylinder. You must evacuate from both sides.
5. Once the pressures have equalized, valve off the refrigerant gauges and the recovery cylinder securely.
6. Carefully remove the refrigerant hose from the recovery cylinder.
7. Zero out the refrigerant scale and weigh the recovery cylinder. Note this weight.
8. Subtract the empty tank weight recorded from the cylinder now containing the refrigerant. This will be the amount recovered.
NOTE: You can check Serial Label to verify any leak.
9. A recovery cylinder containing R-290 can be vented outdoors. See "Venting R-290" for instructions on venting R-290.
10. After venting the refrigerant, purge the recovery cylinder with nitrogen at a flow rate of 5PSIG through the liquid port of the recovery cylinder for 2 minutes outdoors, 3 metres away perimeter from any structures or ignition sources.
11. Repeat steps 1-9 until the recovery cylinder and the system equalize into a vacuum.

NOTE: Trace amounts of R-290 will remain trapped in the POE oil of the compressor.

Venting R-290

TOWER SERIES CABINETS - APPENDIX A
R-290 Refrigerant

-
- | | |
|---------------------------|--|
| Venting Procedures | <ol style="list-style-type: none"> 1. Do NOT vent hydrocarbon refrigerants inside a building under any circumstance (SAFETY RISK). 2. Venting hydrocarbon refrigerants to a public area or where people are unaware of the procedure is not permitted. 3. When venting R-290 YOU MUST make everyone in the immediate area aware that you are venting a flammable gas to the atmosphere. 4. Ensure there are no ignition sources within a 10 ft. perimeter of the area you are venting R-290. Be aware that E-cigarettes or similar electronic devices could be a source an ignition. 5. Ensure that all local legislation/regulations addressing safety of hazardous or flammable substances are satisfied. 6. Ensure you are not venting R-290 into a low-lying area. R-290 is heavier than air and can accumulate in floor drains, grease traps, piping troughs, etc. 7. After venting, purge with Nitrogen through the system for a minimum of 10 seconds. |
|---------------------------|--|
-

System Evacuation

TOWER SERIES CABINETS - APPENDIX A
R-290 Refrigerant

-
- | | |
|--------------------------|---|
| Preliminary Tasks | <p>Prior to sealing up the system make sure you have a sufficient amount of service access tubing remaining for service in the future.</p> <ol style="list-style-type: none"> 1. Remove the crimped tubing and piercing/saddle valve from the process tube. 2. Extend the process tube a minimum of 30cm. 3. Crimp and braze the process tube extension. 4. Install piercing/saddle valve just before last crimp. <p>After the system has been sealed and leak checked, it is necessary to evacuate it in order to remove air, moisture, and unwanted residual refrigerant.</p> |
|--------------------------|---|
-

NOTE **Technician must use tube cutter instead of torch when removing refrigeration system components.**

CUSTOM

7-ELEVEN TOWER CABINETS
REFRIGERATED

System Evacuation cont.

TOWER SERIES CABINETS - APPENDIX A
R-290 Refrigerant

Evacuation Procedure

1. It is necessary to purge the system with nitrogen. This is necessary to prevent flammable mixtures from occurring.
 2. When connecting the hoses between the system, gauge manifolds, and vacuum pump, ensure that the connections are secure and there are no potential ignition sources nearby.
 3. Ensure that the pump discharge is in an area free of potential ignition sources.
 4. Ensure that a micron gauge is used since conventional manifold gauges may not provide a proper reading.
 5. The system should be evacuated to the desired pressure (typically 250 microns or less) and then left to stand for 15 minutes to ensure that the entire refrigerant charge has been removed from the oil and any residual moisture has been evaporated from the system.
 6. Ensure that the vacuum pump is of good quality and of appropriate capacity for the system, and the oil level is correct.
-

Charging the System

TOWER SERIES CABINETS - APPENDIX A
R-290 Refrigerant

WARNING

Dial-a-charge cylinders, with a sight glass, should not be used to charge systems with flammable refrigerant.

Precautions

Although charging procedures are similar to those used with any other type of refrigerant, the following considerations are important for R-290:

- Prior to charging, ensure the system has been leak checked.
- Hoses or lines must be as short as possible to minimize the amount of refrigerant contained in them.
- Evacuate the hoses and manifold prior to charging to avoid contamination of the refrigerant.
- Upon completion of charging, a further leak check must be carried out prior to leaving the site.
- After charging, carefully disconnect the hoses, attempting to minimize the release of refrigerant.
- After charging, all access ports/points must be removed following the correct procedures.

**DO NOT OVERCHARGE A SYSTEM USING R-290.
Weigh in the exact charge.**

Removal and Sealing of Access Ports

TOWER SERIES CABINETS - APPENDIX A
R-290 Refrigerant

CAUTION Do not leave piercing valves on the system.

Procedure

1. Pinch line off just before the temporary access port two times using a crimping tool. Keep crimping tool in place as shown in photo.
2. Verify that there are no leaks.
3. Remove the piercing valve/temporary access port.
4. Snap off at "crimp 1" and check for leaks.
5. Braze open end shut while crimping tool is in place.
6. Leak check the system, with crimping tool removed.



Electrical Repairs

TOWER SERIES CABINETS - APPENDIX A
R-290 Refrigerant

CAUTION The electrical power to the equipment must be disconnected. A combustible-gas leak detector must be on at all times.

Protect yourself from hazards of working on the electrical components by following some basic guidelines before you begin the repair. Prior to starting your repair work on an electrical component, use your combustible gas detector to see if flammable gas is present.

Only when the area is clear of any flammable gas should you start the repair.

Guidelines

- Do not use components that produce sparks, discharge, etc.
- Components that could produce a potential ignition source need to be positioned in an area, distant and unreachable, from any potential refrigerant leak.
- FPG components are designed for use with flammable refrigerants.
- Do not replace faulty components that are intended not to spark with components that do. ONLY use FPG recommended spares.
- Do not modify components that are intended not to spark in such a way that they will spark.

CUSTOM

7-ELEVEN TOWER CABINETS
REFRIGERATED

Electrical Repairs cont.

TOWER SERIES CABINETS - APPENDIX A
R-290 Refrigerant

Check General Condition

You may not be the first person that has worked on this system.

- Check all components for unauthorized/non-OEM replacement parts.
 - Look beyond your repair for any wear, stresses, that could become an ignition source. Are terminal connections tight and in a UL approved connectors?
 - Check all protective conductors' connections each time you access a system or repair is made.
 - Finally, check the plug, cabling and wiring for any damage.
-

R-290 SERVICING FLOW CHART

Before starting work on the R-290 system, turn on the gas-leak detector and place it on the floor, next to the cabinet.

	Refrigeration Circuit Access	Comments
1	Disconnect electrical supply to appliance.	If possible, ground the appliance to avoid static electric sparks.
2	Access condenser/compressor and install two piercing valves.	Vent both the high and low side of the system in case there is a blocked cap tube and/or drier.
3	Connect your refrigeration gauge equipped with 30cm hoses to the two piercing valves.	
4	Connect the yellow hose of your gauge set to a recovery bag or a venting tube, if a safe venting location is available.	
5	Once the charge is removed, connect the Nitrogen tank.	
6	Purge Nitrogen through the system for a min. of 10 seconds.	If using a recovery bag, be sure to take it to a safe location and vent.
7	Always cut the compressor or other components out with a tubing cutter.	
8	Purge Nitrogen through the system at 70 to 140 hPa, before any parts must be un-brazed.	
9	Purge Nitrogen through system at 70 to 140 hPa, while brazing in new components.	

CUSTOM

7-ELEVEN TOWER CABINETS REFRIGERATED

	Installing New Components	Comments
1	Remove old compressor, drier and any other defective component.	If the compressor is removed, seal the suction and discharged tubes to prevent a spill.
2	Install new FPG approved spare parts.	A new dryer must be fitted if the compressor is replaced.
3	If the two access line tubes are not at least 30cm long, add more tube with brazed pinched-off ends. Reinstall tap valves.	Access tubing lines may need to be braced to prevent bending over.
4	Purge with Nitrogen again at 70 to 140 hPa while brazing. Wrap drier with wet rag when brazing.	
5	Fill the system with Nitrogen to 1000 kPa and check for leaks.	
6	Release Nitrogen and pull a vacuum on the system to 250 microns or less. Turn off the vacuum and confirm that it holds the vacuum.	
7	If vacuum holds, the system can now be charged.	Propane labelled 'R-290 Refrigerant' must be used. DO NOT USE BBQ PROPANE.
8	Purge the charging hoses and ready your gauge set and hoses so they will not move during the charging process.	
9	Check the cabinet Serial Number label for the required charge.	
10	Use the ball valves installed on your hose to meter in the charge.	Because the charge is small, take care and be precise.
11	Charge the circuit. (preferred method of charging is to charge liquid into liquid line).	
12	If new starting components have been fitted, check electrical connections and install all terminal covers.	FPG compressor start components are designed for use with HC refrigerants. Do not use non-FPG approved spare parts.
13	Start the system and check operation. Do a final check for leaks	

7-ELEVEN TOWER CABINET

Revision History

Revision Level	Date of Change	Change Details
A	26/11/24	New manual using VSD compressor

PRODUCT MANUAL 33972

REV A NOV 2024

In line with our policy to continually develop, improve and support our products, Future Products Group Ltd reserves the right to change specifications and design without notice.

Have a question? Please email us at: sales@fpgworld.com or visit www.fpgworld.com for full contact details for your region.

Worldwide
contact
details:

