



FPGWORLD.COM



# INLINE

## 5000 SERIES 1500 FREESTANDING/CURVED HEATED



RANGE	INLINE 5000 SERIES	
TEMPERATURE	HEATED	
MODEL	IN-5H15-CU-TF-FS	IN-5H15-CU-SD-FS
FRONT	CURVED/ TILT FRONT	CURVED/ SLIDING DOORS
INSTALLATION	FREESTANDING	
HEIGHT	1443mm	
WIDTH	1507mm	
DEPTH	789mm	

TEMPERATURE RANGE	+55°C - +95°C
RECOMMENDED CORE PRODUCT TEMPERATURE	+65°C - +80°C
ENVIRONMENTAL TEST CONDITIONS	22°C / 65% RH



## FEATURES

-  **High energy efficiency: 3.1 kWh per hour (average)**
-  **Cabinet operating temperature range +55°C - +95°C  
Recommended core product temperature +65°C - +80°C**
  - Smart display with double-glazed glass encased in brushed stainless steel frame

### Tilt Front or Sliding Doors Heated Display

-  Three tiltable, height-adjustable stainless steel wire rack shelves are full cabinet width to support maximum display capacity
-  25,000 hour LED lighting system at 2758 lumens per metre in cabinet top and to each shelf
  - Unique shelf mounted ticket strip front and rear: 30mm

### Operational Excellence

-  Sliding doors (staff side) and tilt front or sliding doors options (customer side)
-  Constructed from stainless and mild steel with fully double-glazed, toughened safety glass for maximum energy efficiency and durability
-  Low wattage density element provides even temperature distribution
  - Designed to be installed into joinery
  - Fitted with adjustable 150mm legs (+30mm adjustment)



Showing : Inline 5000 Series heated 1500mm curved freestanding tilt front

## OPTIONS & ACCESSORIES

Contact a [FPG Sales Representative](#) for our full range, including:

- Shelf trays: Toughened safety glass or mild steel. Colour and woodprint options available for steel shelf trays
- Stainless steel product trays with three sides
- Stainless steel pie chutes
- Additional shelf
- Ticket strip to base: 30mm
- Branded decals
- Rear door or end glass mirror application
- Adjustable 100mm legs (+25mm adjustment), lockable castors or unidirectional rollers
- External stainless steel chassis surround
- Rear deck assemblies
- Custom joinery solution



Please contact FPG to discuss your requirements for meeting country-specific standards.

FPGWORLD.COM

### HEATED DATA

MODEL	TEMPERATURE RANGE	RECOMMENDED CORE PRODUCT TEMPERATURE	ENVIRONMENTAL TEST CONDITIONS	HEATING
IN-5H15-CU-XX-FS	+5°C – +95°C	+65°C – +80°C	22°C / 65% RH	Low wattage density element

### ELECTRICAL DATA

MODEL	VOLTAGE	PHASE	CURRENT	E24H (kWh)	kWh per hour (average)	IP RATING	MAINS		LED LIGHTING		
							CONNECTION	CONNECTION PLUG	HOURS	LUMENS	COLOUR
IN-5H15-CU-XX-FS	220-240 V	Single	20.2 A	74.4	3.1	IP 22	Fixed wiring <sup>1</sup>	N/A	25,000	2758 per metre	Natural

<sup>1</sup>Please see the manual for more information.

### CAPACITY, ACCESS & CONSTRUCTION

MODEL	DISPLAY AREA	LEVELS	ACCESS FRONT	ACCESS REAR	CHASSIS CONSTRUCTION
IN-5H15-CU-TF-FS	18 m <sup>2</sup>	3 Shelves	Tilt front	Sliding doors	Stainless 304 and mild steel
IN-5H15-CU-SD-FS	18 m <sup>2</sup>	3 Shelves	Sliding doors	Sliding doors	Stainless 304 and mild steel

### DIMENSIONS

MODEL	H x W x D mm (Uncrated)	MASS (Uncrated)
IN-5H15-CU-XX-FS	1443 x 1507 x 789	181 kg

Crated weights and dimensions vary. Please contact us for information on your shipment.

#### Installation note:

Model cutout dimensions: IN-5H15-CU-XX-FS models require 1460 x 725mm benchtop cutout. Joinery height 603mm (see product manual for installation guide).

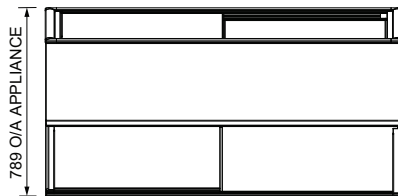

PLAN VIEW

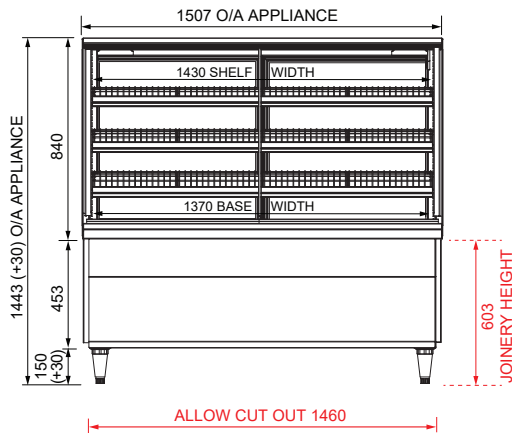

FRONT ELEVATION

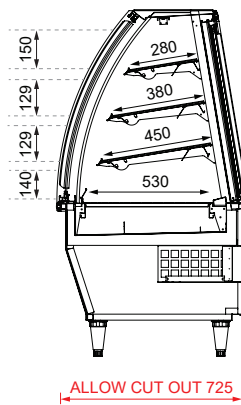

SECTION VIEW

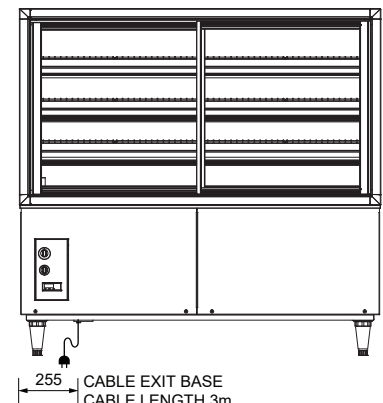

REAR ELEVATION

More information including technical data and installation guidelines is available from the Product Manual published on our website.

In line with our policy to continually develop, improve and support our products, Future Products Group Ltd reserves the right to change specifications and design without notice.

Have a question? Please email us at [sales@fpgworld.com](mailto:sales@fpgworld.com) or visit [www.fpgworld.com](http://www.fpgworld.com) for full contact details for your region.

