



FPGWORLD.COM

INLINE

3000 SERIES 1200 FREESTANDING/SQUARE HEATED

RANGE	INLINE 3000 SERIES	
TEMPERATURE	HEATED	
MODEL	IN-3H12-SQ-FF-FS	IN-3H12-SQ-SD-FS
FRONT	SQUARE/ FIXED FRONT	SQUARE/ SLIDING DOORS
INSTALLATION	FREESTANDING	
HEIGHT	1272mm	
WIDTH	1200mm	
DEPTH	662mm	

TEMPERATURE RANGE	+30°C - +90°C
RECOMMENDED CORE PRODUCT TEMPERATURE	+65°C - +80°C
ENVIRONMENTAL TEST CONDITIONS	22°C / 65% RH

FEATURES

- High energy efficiency: 1.1 kWh per hour (average)
- Cabinet operating temperature range +30°C - +90°C
Recommended core product temperature +65°C - +80°C

- Smart display with double-glazed glass finished with a black trim

Fixed Front or Sliding Doors Heated Display

- Two tilttable, height-adjustable stainless steel wire rack shelves are full cabinet width to support maximum display capacity
- 25,000 hour LED lighting system at 2758 lumens per metre in cabinet top
- Unique shelf mounted ticket strip front and rear: 30mm

Operational Excellence

- Sliding doors (staff side) and fixed front or sliding doors options (customer side)
- Constructed from stainless and mild steel with fully double-glazed, toughened safety glass for maximum energy efficiency, climate control and durability
- Low wattage density element provides even temperature distribution
- Fitted with adjustable 150mm legs (+30mm adjustment)



Showing : Inline 3000 Series heated 1200mm square freestanding fixed front

OPTIONS & ACCESSORIES

Contact a [FPG Sales Representative](#) for our full range, including:

- Shelf trays: Toughened safety glass or mild steel. Colour and woodprint options available for steel shelf trays
- Stainless steel product trays with three sides
- Stainless steel pie chutes
- Additional shelf
- Ticket strip to base: 30mm
- 25,000 hour LED lighting to shelves
- Branded decals
- Rear door or end glass mirror application
- Adjustable 100mm legs (+25mm adjustment), lockable castors or unidirectional rollers
- Forward facing controls
- Rear deck assemblies
- Custom joinery solution



Please contact FPG to discuss your requirements for meeting country-specific standards.

FPGWORLD.COM

HEATED DATA

MODEL	TEMPERATURE RANGE	RECOMMENDED CORE PRODUCT TEMPERATURE	ENVIRONMENTAL TEST CONDITIONS	HEATING
IN-3H12-SQ-XX-FS	+30°C – +90°C	+65°C – +80°C	22°C / 65% RH	Low wattage density element

ELECTRICAL DATA

MODEL	VOLTAGE	PHASE	CURRENT	E24H (kWh)	kWh per hour (average)	IP RATING	MAINS		LED LIGHTING		
							CONNECTION	CONNECTION PLUG ¹	HOURS	LUMENS	COLOUR
IN-3H12-SQ-XX-FS	220-240 V	Single	71 A	26.4	11	IP 20	3 metre, 3 core cable	10 amp, 3 pin plug	25,000	2758 per metre	Natural

¹Please advise country to change plug specification.

CAPACITY, ACCESS & CONSTRUCTION

MODEL	DISPLAY AREA	LEVELS	ACCESS FRONT	ACCESS REAR	CHASSIS CONSTRUCTION
IN-3H12-SQ-FF-FS	0.67 m ²	2 Shelves	Fixed front	Sliding doors	Stainless 304 and mild steel
IN-3H12-SQ-SD-FS	0.67 m ²	2 Shelves	Sliding doors	Sliding doors	Stainless 304 and mild steel

DIMENSIONS

MODEL	H x W x D mm (Uncrated)	MASS (Uncrated)
IN-3H12-SQ-XX-FS	1272 x 1200 x 662	- kg

Crated weights and dimensions vary. Please contact us for information on your shipment.

Installation note:

Model cutout dimensions: IN-3H12-SQ-XX-FS models require 1208 x 668 benchtop cutout. Joinery height 652mm (see product manual for installation guide).

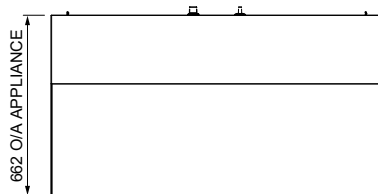

PLAN VIEW

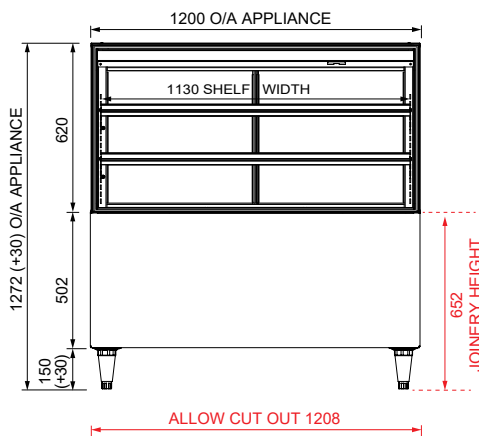

FRONT ELEVATION

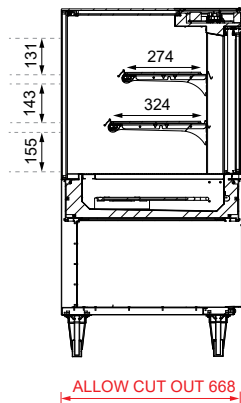

SECTION VIEW

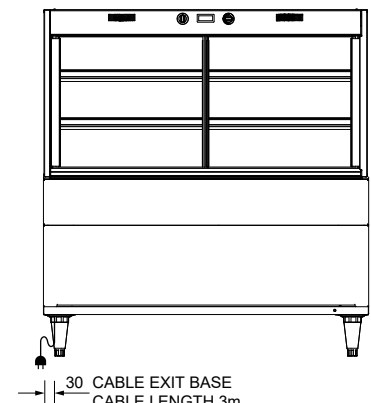

REAR ELEVATION

More information including technical data and installation guidelines is available from the Product Manual published on our website.

In line with our policy to continually develop, improve and support our products, Future Products Group Ltd reserves the right to change specifications and design without notice.

Have a question? Please email us at sales@fpgworld.com or visit www.fpgworld.com for full contact details for your region.

Worldwide
contact
details:

