



For leaders
in food retail



**Trusted.
For Life.**



Trusted.
For Life.



BE UNIQUE STAND OUT

IGA CAULFIELD, AUSTRALIA - ISOFORM GRAB&GO REFRIGERATED/REFRIGERATED 2400

ISOFORM GRAB&GO

Grow your sales, improve your margin.

Isoform Grab&Go is an impressive food and beverage display. Innovative food retailers will appreciate its edgy design, optimised capacity, and clever operational features for improved productivity and health and safety.

Present your premium refrigerated or heated fresh product ranges across two zones: serve-over top display and self-service bottom display. Cross merchandise and upsell on a small footprint. Grow your sales and improve your margin.

Designed on the Isoform platform by FPG.

Create a display that is entirely yours.

A premium display that reflects your brand, your identity.

Isoform. Create something exceptional.



MODULARITY

Available in two widths of 1200mm and 2400mm, Isoform Grab&Go cabinets are available in three temperature configurations:

Tilt front serve-over top display	Open front self-serve bottom display
Refrigerated	Refrigerated
Heated	Refrigerated
Heated	Heated

There are two cabinet height options: 1350mm and 1450mm.

For cabinets with refrigerated displays the cabinet height is determined by whether the cabinets are integral 'plug and play'¹ or are connected to a remote refrigeration system².

Grab&Go temperature combinations	1350mm height		1450mm height	
	✓	Remote Refrigeration	✓	Remote Refrigeration or Integral
Refrigerated Top Display Refrigerated Bottom Display	✓	Remote Refrigeration	✓	Remote Refrigeration or Integral
Heated Top Display Refrigerated Bottom Display	✓	Remote Refrigeration	✓	Remote Refrigeration or Integral
Heated Top Display Heated Bottom Display	✓	–	✓	–

Both cabinet heights will line up beautifully with Isoform Counter cabinets so you can strike an impressive display of mixed Isoform cabinets.

¹Integral refrigeration is where a scroll compressor is installed for the supply of refrigerant. ²Remote refrigeration is where the refrigerant is piped to multiple appliances from an external refrigeration system.



L-R: ISOFORM COUNTER HEATED 1200, ISOFORM COUNTER REFRIGERATED 1200, ISOFORM GRAB&GO REFRIGERATED/REFRIGERATED 1200



Trusted.
For Life.

EXCEPTIONAL MERCHANDISING

Create impact.

Use your imagination to create a unique, enticing display.

Stop your customers in their tracks.

Make a statement.

The cabinet aesthetics are striking.

Start with the super slim black chassis and frame of Isoform Grab&Go. The high-quality double-glazed safety glass gleams, and the silver pinstripe adds finesse. A cabinet that has presence for those who want the best.

High visibility.

High capacity Isoform Grab&Go cabinets maximise display space and provide excellent line of sight for your customers.





Use displayware to stunning effect.

In the top display, contrast the black powdercoated shelf trays with your bowls and platters. Experiment with different heights, textures, colours and materials – melamine, ceramic, wood, acrylic and glass – to give you true versatility when designing your refrigerated display.

Explore options in glass and stainless steel for heated top displays.

Convenient 'grab and go'.

The open front bottom display includes a wide base and shelf for pre-packaged 'grab and go' food and drinks.

The bottom display provides a generous drinks capacity:

Cabinet width	No. of upright buddy bottles: 70mm diameter, height up to 230mm
1200mm	84
2400mm	175

MERCHANDISING BRILLIANCE

Light it up!

The visual appeal of food and drink merchandise is significantly enhanced by super bright, energy efficient LED lighting. Cleverly engineered by FPG to function in heated cabinets too.

With extended lifetimes, FPG LED lights keep the focus on your merchandise:

Refrigerated: 50,000 hours / Heated: 25,000 hours



NATURAL WHITE (default)



WARM WHITE (option)

Create something exceptional.

FPG can help you to explore the options to boost your brand presence and operational efficiency (minimum order quantity may apply).



NEW WORLD HOBSONVILLE, NEW ZEALAND - ISOFORM GRAB&GO REFRIGERATED/REFRIGERATED 2400 (MULTIPLXED)

MAKE IT YOUR OWN

There are many opportunities to create a merchandising display that excels in attracting customer attention, supports increased sales, and fits your business model. Talk to FPG about your needs and wants.

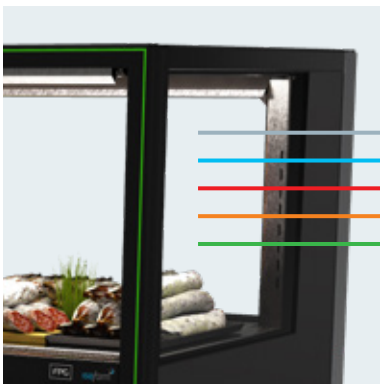

CHOOSE YOUR PINSTRIPE

Choose one of five available cabinet pinstripe colours – silver (default), blue, red, orange, or green.

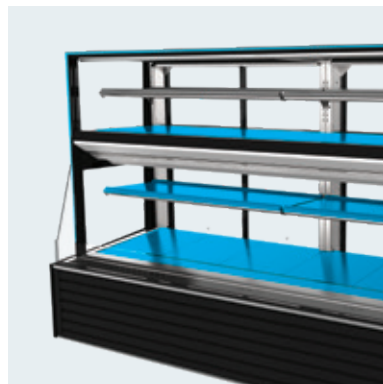

COLOUR

Specify a colour for the cabinet base and shelves to create impact. Complement your cabinet pinstripe and displayware.



WOODPRINT

Apply woodprint to the cabinet base and shelves to create a warm, appealing display.

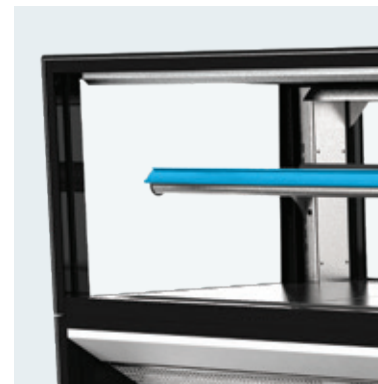

SHELF TICKETING

Add the finishing touch by specifying a different colour or adhesive 'wallpaper' for your shelf ticket strips.



MIRROR GLASS

Request mirror glass for the sides and/or cabinet rear help to create a fuller looking display and to provide a greater degree of privacy to operations behind the cabinet.



BRANDED DECALS

Apply decals to boost your brand presence.



ADDITIONAL SHELF

Expand capacity in the top display by adding an extra shelf.

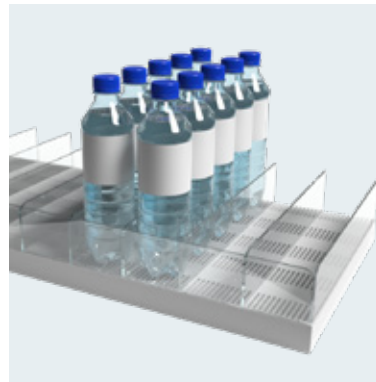

GRAVITY FEED MATTING FOR REFRIGERATED DRINKS

Best-in-class merchandising of refrigerated drinks in the bottom display. Enables staff to re-stock from the rear with bottles facing up at the front. Great presentation that will help you to sell more.



TRAYS AND CHUTES FOR HOT PRODUCT

In heated displays, request drip trays for hot cooked chickens to make cleaning easy. Add chutes for pies and other products to improve presentation and customer selection.



ENHANCE MOBILITY

If maneuverability is important, replace the unidirectional twin rollers and stabilisers on the cabinet with heavy duty lockable castors.

UNPRECEDENTED ACCESS

Unique rear Isoform Dual Action Doors offer the best of both worlds – they slide smoothly for serving and they swing for full width access to the cabinet for restocking or cleaning.

No more heavy lifting of doors. The fast and easy access options save time and prevent the risk of injury and breakage.







IGA CAULFIELD, AUSTRALIA - ISOFORM GRAB&GO REFRIGERATED/REFRIGERATED 2400

COMPLIANCE ASSURED



Enjoy peace of mind. All FPG cabinets are tested in our environmental test laboratory to deliver core consistent product temperatures:

Cabinet type	Average core product temperature	Environmental test conditions
 Refrigerated	+2°C to +4°C	Climate Class 3: 25°C / 60% RH
 Controlled Ambient	+16°C to +18°C	Climate Class 3: 25°C / 60% RH
 Heated	+65°C to +80°C	22°C / 65% RH

Guaranteed core product temperatures
– 24 hours a day, 365 days the year –
 for the lifetime of the cabinet.

TRUSTED FOR LIFE

Every element of Isoform Grab&Go has been designed to deliver core product temperatures while optimising energy efficiency and extending shelf life. Not only does this combination result in the lowest total cost of life, it also supports other sustainability outcomes.

High energy efficiency.

Isoform Grab&Go cabinets have been engineered for high energy efficiency for both refrigerated and heated display zones. Less power demand equates to lower power costs and reduced demand on power-generating natural resources.

How do we achieve this?

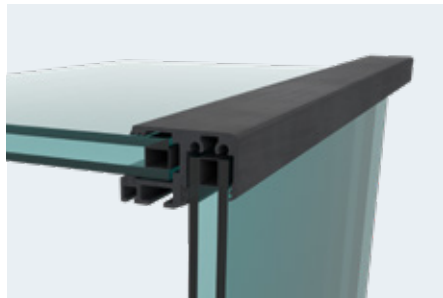

Our innovative use of materials, double-glazing, and passive thermal breaks ensure insulation is optimised.



In refrigerated cabinets, FPG selects energy efficient components such as brushless EC fans and horizontal scroll compressors together with a quality controller which automates the on/off refrigeration cycle.



In heated top displays, gentle fan-assisted Thermofin technology has the advantages of fast heat up times and consistent temperatures across the whole of the display. This enables the temperature set point to be reduced which means lower power use, lower power bills.

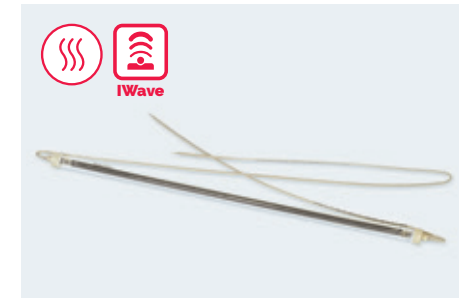

In heated open front bottom displays, FPG's unique quartz infrared IWave heating system pulses energy providing very consistent core product temperatures. The energy pulsed does not heat up the air – it targets organic matter on the shelf. As a result, IWave has very high energy efficiency.

Power usage varies across the Grab&Go range. For information, please refer to spec sheets available from the FPG website.



**Trusted.
For Life.**

Reduce food wastage and increase shelf life up to 200%.

A natural consequence of refrigeration and heating is drying out food. FPG has engineered:

- Humidity management to help food retain moisture in enclosed refrigerated cabinets.
- Gentle consistent heating for holding hot food at its core product temperature. Other cabinets have short, high-temperature heating coils which cause hot spots where the food continues to cook and dry out. FPG heated cabinets have longer, lower-temperature coils that deliver even, gentle heating.

Easy to clean.

All parts and areas that need cleaning are easily accessible by staff. On the top display, tilt the front forward to access the glass for cleaning. Use the swing function of the Dual Action Doors for excellent access to the interior.

With regular cleaning of the pre-filter in cabinets with integral refrigeration, not only can you save on technical support costs, you'll also be ensuring the refrigeration system is performing at its best and in so doing, extending its life.



Preventative maintenance and warranty.

For those cabinets with integral refrigeration, quarterly preventative maintenance will maintain the energy efficiency of the cabinet, extend the life of the cabinet, and keep your warranty valid. Annual service checks of heated cabinets and cabinets connected to remote refrigeration systems are highly recommended to ensure your cabinet is operating optimally.

The warranty term is one year for all cabinets. For cabinets with integral refrigeration, the condenser has a warranty term of three years. Warranty terms and conditions are published in the manual.

Well supported.

FPG Technical Support is available online and by phone. We publish online resources to support the technical service providers of our customers. These include 'How To' videos and comprehensive manuals. We also offer training via online platforms and recommend the spare parts the service provider should hold locally to service the cabinets.

FPG stands by our cabinets for their lifetime. That means spare parts and support will always be available to your technical service provider.



End-of-life recycling.

Cabinets can be dismantled and the components such as the sheet metal and glass can be recycled. We estimate up to 85% by volume can be recycled.

FPG engineers all cabinets to meet international standards.

International safety standards for electrical refrigerated appliances: IEC 60335-1, IEC 60335-2-89, and the equivalent country-specific standards including AS/NZS and BS EN.

International safety standards for electrical heated appliances: IEC 60335-1, IEC 60335-2-49, IEC 60335-2-50 and the equivalent country-specific standards including AS/NZS and BS EN.

International standards for electromagnetic compatibility/emissions: CISPR 14-1, and the equivalent country-specific standards including AS/NZS CISPR and BS EN 55014-1.

Essential safety requirements: AS/NZS 3820 and AS/NZS 4417.

Energy efficiency for refrigerated appliances: MEPS (Australia/New Zealand).



Some countries permit self-declaration while other countries may require external testing and certificates of conformity.

Please contact us for more information.

OPTIONS

Two widths, two heights and three temperature configurations.

For cabinets with refrigerated displays height options are determined by whether the cabinets are integral¹ or are serviced by a remote refrigeration system².

Width: 1200mm

I-GG-HH-12-13

Width: 2400mm

I-GG-HH-24-13

Height: 1350mm

Tilt front, serve-over top display:	Heated
Open front, self-serve bottom display:	Heated

Width: 1200mm

I-GG-HR-12-13

Width: 2400mm

I-GG-HR-24-13

Height: 1350mm

Tilt front, serve-over top display:	Heated
Open front, self-serve bottom display:	Refrigerated: Remote Refrigeration

Width: 1200mm

I-GG-RR-12-13

Width: 2400mm

I-GG-RR-24-13

Height: 1350mm

Tilt front, serve-over top display:	Refrigerated: Remote Refrigeration
Open front, self-serve bottom display:	Refrigerated: Remote Refrigeration

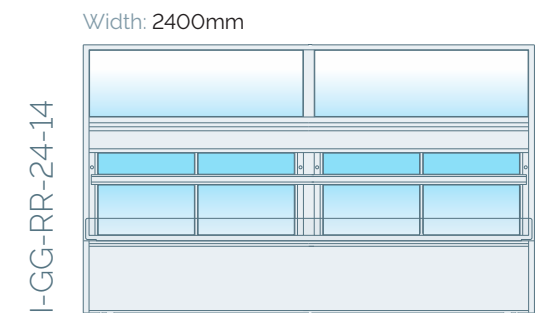
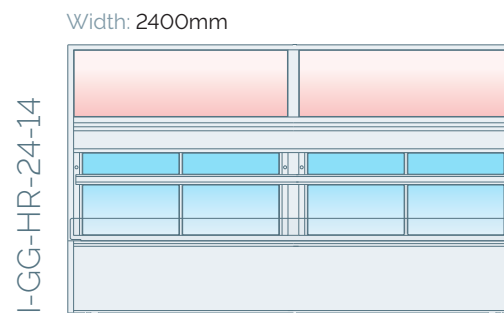
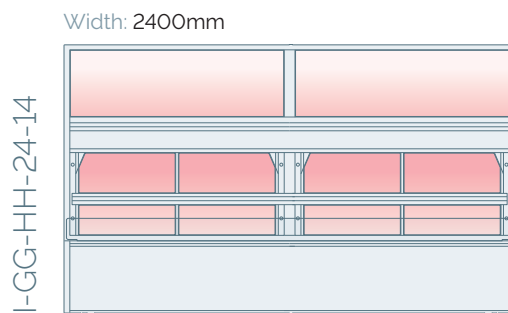
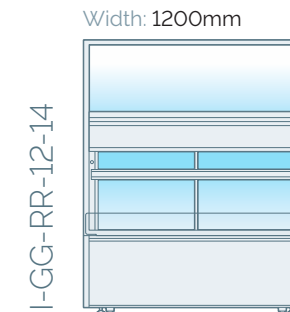
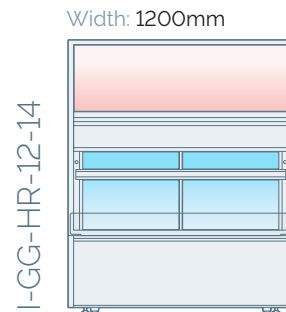
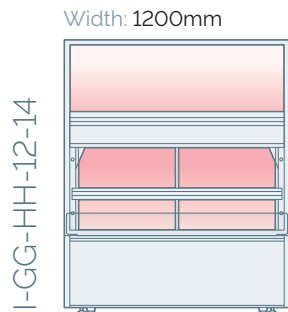

Height: 1450mm

Tilt front, serve-over top display: Heated

Open front, self-serve bottom display: Heated

Height: 1450mm

Tilt front, serve-over top display: Heated

Open front, self-serve bottom display: Refrigerated: Remote or Integral Refrigeration

Height: 1450mm

Tilt front, serve-over top display: Refrigerated: Remote or Integral Refrigeration

Open front, self-serve bottom display: Refrigerated: Remote or Integral Refrigeration

¹Integral refrigeration is where a scroll compressor is installed for the supply of refrigerant. ²Remote refrigeration is where the refrigerant is piped to multiple appliances from an external refrigeration system.



**Trusted.
For Life.**



C-STORE



CAFÉ/BAKERY
OSR



FMCG



HOSPITALITY



SPECIALTY
FOOD SERVICE



SUPERMARKET

Worldwide
contact
details:



fpgworld.com
sales@fpgworld.com