

MODELS IL-MD-600/900-REF-SQ

PRODUCT MANUAL 33308
REV C NOV 2024



CUSTOM

McDONALD'S INLINE
HORIZONTAL SPLIT CABINET
REFRIGERATED: R-290 **VSD**

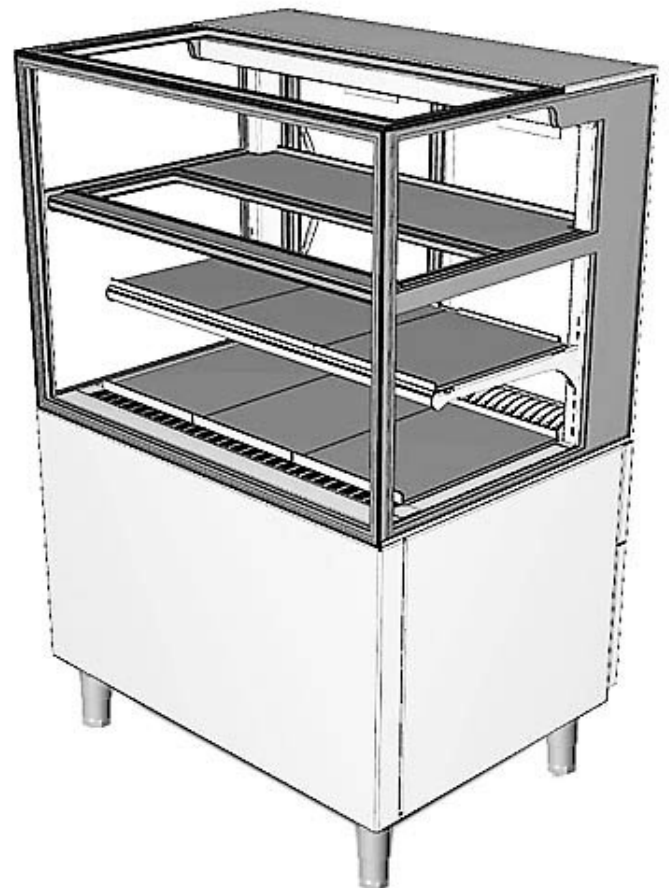

WIDTHS: 600/900mm
FIXED FRONT/SLIDING REAR DOORS
INTEGRAL REFRIGERATION

Warnings

Operational Safety

This appliance is not intended for use by young children or infirm persons, unless they have been adequately supervised by a responsible person, to ensure that they can use the appliance safely.

Young children should be supervised, to ensure that they do not play with the appliance.

Function

This cabinet is not designated as a beverage cabinet. It is intended to display food items, chilled in the lower section and ambient temperature in the upper section.

Caution

Do not store explosive substances, such as aerosol cans with flammable propellant, in this appliance.

Mains Supply Cord

If the supply cord is damaged, it must be replaced by the manufacturer, its service agent or similarly qualified persons, in order to avoid a hazard.

Specialist Disposal

Specialist disposal procedures are required for the safe removal of refrigerant gasses and potentially flammable foam materials.

Pentane, Dimethyl Ether, Isobutene, Butane and Propane may be present.

**Copyright © NOV 2024 Future Products Group Limited.
All rights reserved.**

No part of this publication may be reproduced, stored in a retrieval system, or transmitted in any form or by any means, electronic, mechanical, photocopying, recording or otherwise, without the prior written permission of Future Products Group Ltd.



Table of Contents

WARNINGS	2
Operational Safety.....	2
Function.....	2
Caution.....	2
Mains Supply Cord.....	2
Specialist Disposal.....	2
INTRODUCTION	6
Welcome	6
Future Products Group (FPG).....	6
Guidance and Help.....	6
Warranty	6
Warranty Period.....	6
Liability Exceptions.....	7
Specific Exclusions.....	7
Assessment.....	7
Time Limit.....	7
Caution.....	7
OPERATION	8
Cabinet Layout	8
Square Series Cabinets.....	8
Shelf Lighting.....	8
Shelves.....	8
Controls	8
Power, Lights and Refrigeration Controller.....	8
Keyboard Lock.....	8
Preparation	9
Shelf Location and Ticketing.....	9
Shelf Adjustment.....	9
Turn on Refrigeration.....	9
Switch Power and Lights.....	10
Load Cabinet.....	10
Loading Restrictions.....	10
Embraco Sync Information.....	10
Routines	10
After Hours.....	10
Cleaning.....	10
CLEANING	11
Cautions	11
Power.....	11
Water.....	11

CUSTOM

MCDONALDS INLINE

HORIZONTAL SPLIT CABINET/REFRIGERATED

Procedures	11
McDonald's Standard Procedures	11
Sliding Doors	11
Louvers	12
Removable Parts	12
Cleaning the Base Cavity	13
Cooling Fins	13
Temperature Probes	13
Condensate Container	13
Routines	14
Schedules	14
Condenser Assembly	14
INSTALLATION	15
Regulations	15
Compliance with Local Requirements	15
Setting Up	15
Unpacking	15
Level the Cabinet	15
Cabinet Preparation	15
Shelves trays and Rear Shelf	15
Grounding	15
Power Supply	15
SPECIFICATIONS	16
Mechanical	16
Electrical	16
Controller Settings	17
Compliance	17
Safety Aspects	17
Operational Safety	17
Performance Aspects of Refrigerated Cabinets	17
Improvements	17
Ongoing Development	17
ELECTRICAL CIRCUIT DIAGRAMS	18
Model: IL-MD-600-REF-SQ	18
Model: IL-MD-900-REF-SQ	18
SPARE PARTS	19
Cabinet Serial Number	19
*Recommended Spare Parts to be carried by Service Provider	19
MECHANICAL DRAWINGS	21
Model: IL-MD-600-REF-SQ-B100-01	21
Model: IL-MD-900-REF-SQ-B100-01	22
Door Seals	22



APPENDIX A R-290 REFRIGERANT	23
General Guidance	23
R-290	23
Servicing	23
Specialized Training	23
Environment	23
Gas Detector	23
Replacement Parts	23
Fault Diagnosis	23
Check List	23
Servicing	24
Gas Monitor	24
Ignition	24
Danger Sign	24
Fire Extinguisher	24
Access Fittings	24
Electrical Connectors	24
Replacement Components	24
Tools	25
Basic Tools	25
Required Tools	25
Leak Checking	26
Warning	26
Detection Methods	26
Accessing the Refrigeration System	26
Installing Piercing Valves	26
Procedure	26
Recovering Refrigerant	27
Recovery Machines	27
Procedure Without Machine	27
Venting R-290	28
Venting Procedures	28
System Evacuation	28
Preliminary Tasks	28
NOTE	28
Evacuation Procedure	29
Charging the System	29
WARNING	29
Precautions	29
Removal and Sealing of Access Ports	30
CAUTION	30
Procedure	30
Electrical Repairs	30
CAUTION	30
Guidelines	30
Check General Condition	31
R-290 SERVICING FLOW CHART	32
REVISION HISTORY	35

CUSTOM

MCDONALDS INLINE
HORIZONTAL SPLIT CABINET/REFRIGERATED

INTRODUCTION

Welcome

REFRIGERATED CABINETS - INTRODUCTION

Future Products Group (FPG)

Welcome to the world of FPG! Our products are designed and engineered to give you the optimal performance that you deserve with innovative visual merchandising appeal.

We are confident that you will be delighted with your state of the art inline food service cabinet, and that it will become a valued appliance in your store.

Guidance and Help

Any new appliance can seem very complex and confusing at first glance. To ensure you receive the utmost benefit from your new inline cabinet, there are two things you can do.

- Before operating the cabinet, please read the instruction book carefully and follow its recommendations. The time taken will be well spent. These instructions both general and technical tell you how to install, operate and look after your inline food service cabinet so that you can receive the full benefits that this cabinet has to offer.
 - These instructions cannot, however, cover all eventualities. If you are unsure of any aspect of the installation, instructions or performance of your cabinet, contact your dealer promptly or contact us via email to support@fpgworld.com.
-

Warranty

REFRIGERATED CABINETS - INTRODUCTION

Warranty Period

Future Products Group Limited warrants, to the original purchaser of an FPG manufactured food service cabinet, that for TWO YEARS (24 months) from the date of purchase, any defect in workmanship or material resulting in the product malfunctioning while under correct use will be rectified.

For refrigerated cabinets with integral or near-remote refrigeration the warranty is extended to THREE YEARS (36 months), for refrigeration condenser units. Conditions apply, see Liability Exceptions.

Liability under this warranty is limited to replacing or repairing a part, without charge.

Continued on next page

Warranty cont.

REFRIGERATED CABINETS - INTRODUCTION

Liability Exceptions

Liability under this warranty does not include:

- Any loss, damage, or expenses directly or indirectly arising from the use of, or inability to use, the product or from any other cause.
 - Any part of the cabinet which has been subject to misuse, neglect, alteration, incorrect installation, accident, or damage caused by transportation, use of abrasive or caustic chemicals, flood, fire or acts of God.
 - Damage, resulting from failure to have the cabinet regularly serviced by a refrigeration engineer:
 - For cabinets with integral or near-remote refrigeration, every three months. NB: You will be required to provide copies of service records in the event of condenser failure.
 - For cabinets with remote refrigeration, annually.
 - Any damage or malfunction, resulting from the use of non-FPG supplied spare parts.
-

Specific Exclusions

The following are specifically excluded from warranty:

- Breakage of glass or plastic components, or the replacement of LED lighting assemblies or gaskets.
 - Maladjustment of the electronic refrigeration controller, by an unqualified person.
 - For cabinets with integral or near-remote refrigeration, failure resulting from a lack of routine condenser / radiator cleaning.
 - Failure to re-assemble the cabinet correctly after cleaning.
 - Fair wear and tear.
-

Assessment

The liability under this warranty is dependent on an assessment by FPG, to determine the defect in workmanship or materials.

Time Limit

FPG does not guarantee that any service to be performed under this warranty will be carried out within any particular time limit.

Caution

FPG will not be held responsible for any servicing costs incurred prior to FPG's acceptance of a warranty claim.

CUSTOM

MCDONALDS INLINE
HORIZONTAL SPLIT CABINET/REFRIGERATED

OPERATION

Cabinet Layout

REFRIGERATED CABINETS - OPERATION

Square Series Cabinets This Square Series cabinet has a refrigerated main section, with an upper ambient temperature section.

The cabinet has fixed front glass, and rear sliding doors.

The cabinet is Free Standing, with an integral condenser unit.

Condensate is piped to an internal ACR unit.

Shelf Lighting Cabinets are fitted with a top light and lights below each shelf.

Cabinets are fitted with high efficiency LED lighting.

Shelves The lower shelf and base trays are made from stainless steel.

The upper section base is fixed in position.

It is made from coated PVC, and part double glazed glass.

This insulates the upper, ambient section from the chilled lower section.

Controls

REFRIGERATED CABINETS - OPERATION

Power, Lights and Refrigeration Controller The refrigeration controller features a touch-screen display.

The controller regulates the cabinet temperature and controls the automatic defrost cycles.



Keyboard Lock The keyboard is normally locked to prevent accidental parameter changes.

To activate/deactivate the keyboard lock, simply touch all four keys at the same time until the display shows "Loc"/"UnL", respectively.

When a key is touched with the keyboard locked, the display shows "Loc".

The keyboard is automatically locked after 60s of inactivity.

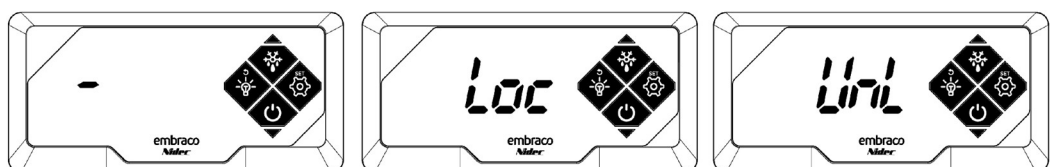

Preparation

REFRIGERATED CABINETS - OPERATION

Shelf Location and Ticketing

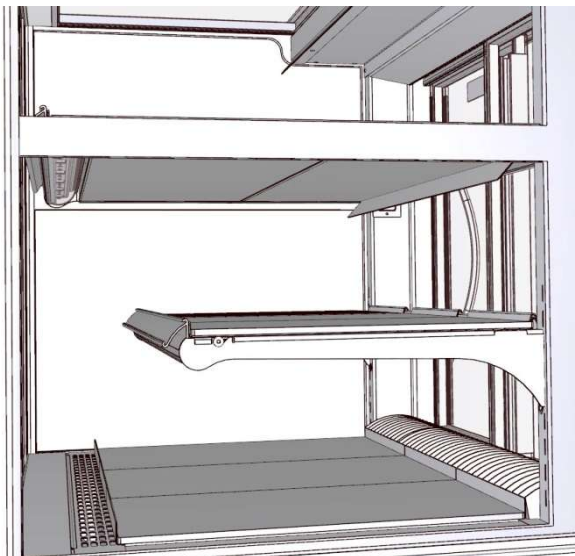

The top base position is fixed.

The lower shelf position is adjustable in height and can easily be moved up or down, to match product size.

The movement is restricted to 50mm, because of the electric cables to the lights. For greater movement contact the manufacturer or supplier for advice, as electrical modifications may be required.

The front and rear edges of the shelves are profiled to carry ticketing/labels.

Shelf Adjustment

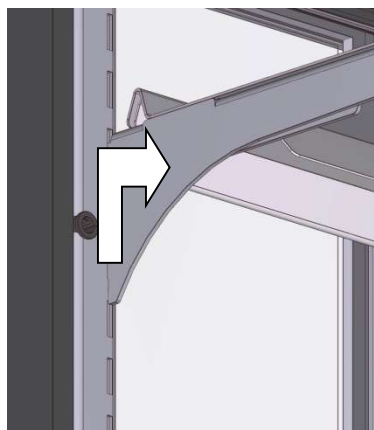

To move the shelf brackets, first remove the shelf trays.

Lift the brackets straight up firmly and then pull the brackets forward, to disengage them from the slots in the support posts.

Insert the brackets into their new position, and push bracket down firmly.

The brackets may be positioned to give two different degrees of slope to the shelf.

Refit the shelf trays and doors.

N.B. Make sure brackets are pushed down as far as they can go. Failure to do this may result in shelf collapse, when loaded with product.

Turn on Refrigeration

The refrigeration condenser will run as soon as the cabinet main switch is turned ON, and the cabinet temperature will begin to fall.

The temperature controller is pre-set to maintain the lower section temperature at 2° - 4° C, and should not need adjustment.

Continued on next page

CUSTOM

MCDONALDS INLINE
HORIZONTAL SPLIT CABINET/REFRIGERATED

Preparation cont.

REFRIGERATED CABINETS - OPERATION

Switch Power and Lights



The temperature controller is pre-set to maintain the cabinet temperature between 2°C and 4°C. It should not need adjustment.

Press the power button for 5s to toggle the cabinet ON OFF.

Press the light button until "Lit" displayed then for 1s to toggle the lights ON and OFF.

Load Cabinet

After the cabinet has run for a 30 minute initial cool-down period, load it with pre-chilled products.

The cabinet is designed to maintain the temperature of pre-chilled products.

If warm product is introduced, there could be a delay before the temperature falls to the normal operating level.

Loading Restrictions

It is important to leave adequate free space for the refrigerated air to circulate within the cabinet.

Allow at least 40mm above canned drinks, or other cylindrical containers.

The air grills at the front of the cabinet must not be covered or restricted.

Embraco Sync Information

Contact FPG for more information about the controller, and to obtain passwords, which may be required to alter settings.

Routines

REFRIGERATED CABINETS - OPERATION

After Hours

Ideally, cabinets should not be turned off after hours or at night. Products can either be left in the cabinet or placed in night storage. Shut the cabinet doors and turn off the lights. The cabinet will then operate on minimum load, and stay cold, ready for instant operation when next required.

If the cabinet is turned off, allow it to run for about half an hour before replacing the pre-chilled products.

Cleaning

Since the cabinet needs to be switched off during cleaning operations, it is best to clean it at the end of the working day. The cabinet will then have time to recover its normal operating temperature, before replacing the products.

CLEANING

Cautions

REFRIGERATED CABINETS - CLEANING

Power **ALWAYS TURN THE POWER SUPPLY OFF BEFORE CLEANING.**

Water THIS UNIT IS NOT WATERPROOF. DO NOT USE A WATER JET SPRAY TO CLEAN THE INTERIOR OR EXTERIOR OF THIS CABINET.

Procedures

REFRIGERATED CABINETS - CLEANING

McDonald's Standard Procedures McDonald's Planned Maintenance, PM cards, should be followed for all regular cleaning procedures.

Sliding Doors



Sliding glass doors are located by plastic guides at the top and bottom.

The doors can be removed for cleaning by sliding the door to a central position, placing hands either side of the door, lifting it up and then swinging it out at the bottom.

When replacing doors, make sure that they are located in the correct slots, top and bottom. The left door should

be in the inner slots, and the right door in the outer slots.

Sliding door tracks should be vacuumed out regularly to keep doors sliding freely.

Continued on next page

Procedures cont.

REFRIGERATED CABINETS - CLEANING

Louvers

Use a vacuum cleaner to remove dust and fluff from the ventilation louvers.

This will maintain the refrigeration efficiency, and prevent overheating.

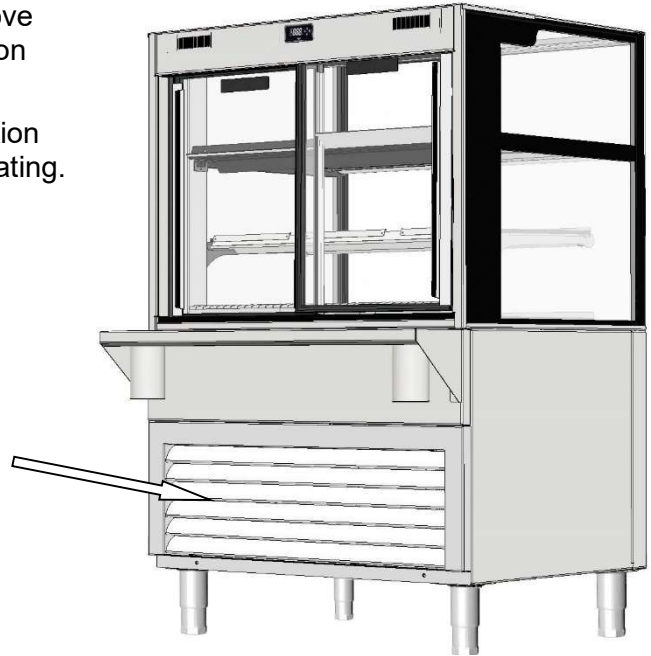

Removable Parts



All of the parts shown above can be removed for cleaning with McD APSC. Stainless steel parts **only** may be cleaned in a dishwasher.

Remove the doors, by sliding them to the centre and lifting, to disengage them from the door tracks.

Continued on next page

Procedures cont.

REFRIGERATED CABINETS - CLEANING

Cleaning the Base Cavity

Remove two screws to release the fan deck and coil cover.

Sweep out, or use a vacuum cleaner, to remove any debris from the cabinet base cavity. **Make sure that the condensate drain hole is clean.**

A Wet-and-Dry vacuum cleaner should be used, since there is likely to be some water in the bottom. Finally, wipe out the bottom with a damp sanitized cloth.

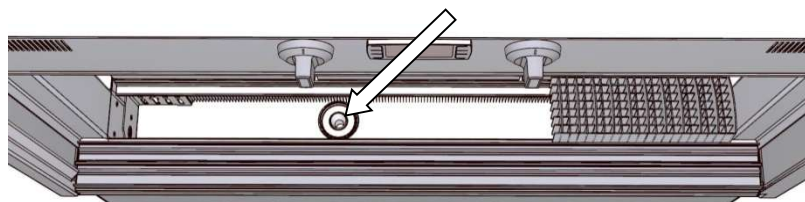

Do not pour water into the base, or the condensate container will overflow.

Cooling Fins

If there is food lodged in the cooling fins, it is best to use a wet and dry vacuum cleaner to suck out the food. **DO NOT** attempt to hose food parts from fins.

Caution: The fins are very sharp. Take extra care when cleaning this area. Do not bend the fins over, as this would restrict the air flow and degrade cabinet performance.



Temperature Probes

Take care not to damage or move the temperature probes, when cleaning the cooling fins. One probe is located on the fan side of the cooling coil, in free air. A second probe is inserted between the fins of the cooling coil on the air exit side.

Do NOT move the probes.

Condensate Container

The condensate container is only designed to handle cooling-coil defrosting liquid that drains from the well.

DO NOT fill the well with liquid, or attempt to hose out as condensate container will overflow and leak onto floor.

Routines

REFRIGERATED CABINETS - CLEANING

Schedules

To maintain optimum performance, regular cleaning schedules should be established, as specified in the McDonald's PM card.

Failure to carry out routine cleaning/servicing schedules will void the warranty on the refrigeration equipment.

Condenser Assembly

For efficient refrigeration performance, the condenser radiator must be kept clean. Failure to do this will lead to a build-up of dust, and restricted airflow will prevent the unit from working properly. The compressor may overheat and the cabinet temperature may rise.

Regular vacuuming will prevent a build-up of dust and fluff, however, three monthly service checks by a refrigeration engineer, which include cleaning the condenser with compressed air, are mandatory.

Be very careful not to bend or damage the soft aluminium fins when vacuuming the radiator. If the fins are flattened, airflow will be restricted and overheating will result.

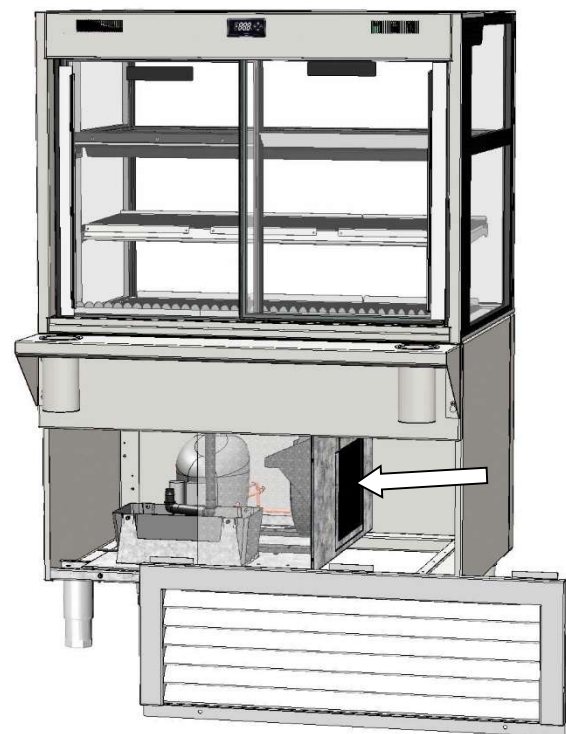

NOTE: The condenser assembly is rotated to face the back on the 600mm cabinet.

INSTALLATION

Regulations

REFRIGERATED CABINETS - INSTALLATION

Compliance with Local Requirements

It is very important that your inline food cabinet is installed correctly and that the operation is correct before use. Installation must comply with local electrical, health & safety and hygiene requirements.

Setting Up

REFRIGERATED CABINETS - INSTALLATION

Unpacking

Unpack and check unit for damage and report any damage to the carrier and supplier. Report any deficiencies to your supplier.

The display cabinet is supplied fully assembled, but shelf trays, inserts and rear shelf are packed separately.

Level the Cabinet

Using a spirit level, adjust the feet to ensure the cabinet is level from side to side and front to back. (If this is not carried out, water may accumulate in the cabinet well, and uneven temperature distribution could also occur).

Cabinet Preparation

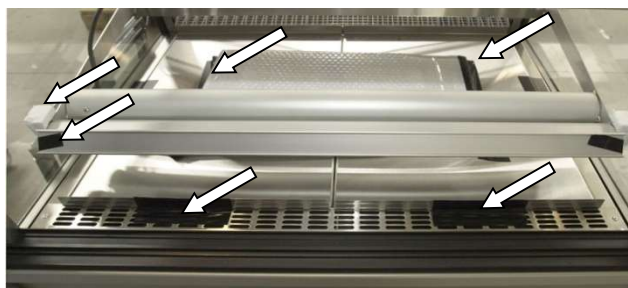

Remove all protective plastic film, tapes, ties and packers, used to prevent movement during transit.

Lift out the deck trays to gain access to the cabinet well. Be sure to replace them as shown.

Shelves trays and Rear Shelf

Assemble the shelf trays and inserts on the support members. Fit the rear shelf and inserts, using the key-hole slots and pre-fitted machine screws.

Grounding

WARNING: THIS APPLIANCE MUST BE GROUNDED TO EARTH

The grounding lead, in the mains cable, must always be connected to earth.

Power Supply

Before connecting to the power supply, check that the local supply is correct to that shown on the rating plate, located on the rear of the cabinet.

CUSTOM

MCDONALDS INLINE

HORIZONTAL SPLIT CABINET/REFRIGERATED

SPECIFICATIONS

Mechanical

REFRIGERATED CABINETS - SPECIFICATIONS

	CABINET MODEL	
	IL-MD-600-REF-SQ	IL-MD-900-REF-SQ
Height	1353 (-0+30) mm	1353 (-0+30) mm
Width	600 mm	900 mm
Depth	664 mm (+150mm shelf)	664 mm (+150mm shelf)
Dry Weight	Approx. 110 kg	170 kg
Cabinet Well Material	Stainless steel	
Cabinet Colour	Black and natural anodised aluminium.	
Top Lighting	Standard	Standard
Shelf Lighting	Standard	Standard
Glass Type	Double glazed	Double glazed
Front Doors	Fixed glass	Fixed glass
Rear Doors	Sliding glass	Sliding glass
Number of Shelves	Two plus base	Two plus base
Ambient Display Area	0.27 m ²	0.4 m ²
Chilled Display Area	0.45 m ² (including base)	0.6 m ² (including base)
Refrigerant	R-290	R-290
Refrigerant charge	see Rating Label	see Rating Label
Condensate capacity	3 litres	3 litres
Climatic Class & IP	All cabinets are suitable for class N climates and have an IP X3 rating	

Electrical

REFRIGERATED CABINETS - SPECIFICATIONS

	CABINET MODEL	
	IL-MD-600-REF-SQ	IL-MD-900-REF-SQ
Voltage	220 - 240 V 50/60 Hz 1 ϕ	220 - 240 V 50/60 Hz 1 ϕ
Power	419 W max	500 W max
Current (max)	1.82 A	2.18 A
Energy Consumption	0.09 kWh/h	0.09 kWh/h
Connection	3 pin plug, 10 A lead	3 pin plug, 10 A lead
Temperature Range	2° - 4° C Lower Section Ambient Upper Section	2° - 4° C Lower Section Ambient Upper Section
Top Lights	1 x LED strip	1 x LED strip
Shelf Lights	2 x LED strips	2 x LED strips

Controller Settings

REFRIGERATED CABINETS - SPECIFICATIONS

Parameter	Description	Settings		Units/Range
		600	900	
t00	Set Point	3	3	deg C
t01	Hysteresis	2	2	deg C

Compliance

REFRIGERATED CABINETS - SPECIFICATIONS

- Safety Aspects** This cabinet has been designed to comply with the relevant requirements of the following specifications:
- IEC 60335-1 Ed 5.2 : Household and similar electrical appliances – Safety-General Requirements.
 - IEC 60335-2-89 Ed 2.2 : Particular requirements for commercial refrigerating appliances with an incorporated or remote refrigerant unit or compressor.

Operational Safety This appliance is not intended for use by young children or infirm persons, unless they have been adequately supervised by a responsible person, to ensure that they can use the appliance safely.

Young children should be supervised, to ensure that they do not play with the appliance.

Performance Aspects of Refrigerated Cabinets The cabinet is HACCP compliant, with the following performance:

Cabinet Operating Temperature	Average Internal Humidity	Test Conditions
+2° to +4°C	70% RH	25°C Ambient with 60% RH

Improvements

REFRIGERATED CABINETS - SPECIFICATIONS

Ongoing Development FPG reserves the right to change specifications and construction, as part of ongoing product improvement.

ELECTRICAL CIRCUIT DIAGRAMS

Model: IL-MD-600-REF-SQ Square Format Series, 600mm Refrigerated Horizontal Split Cabinet

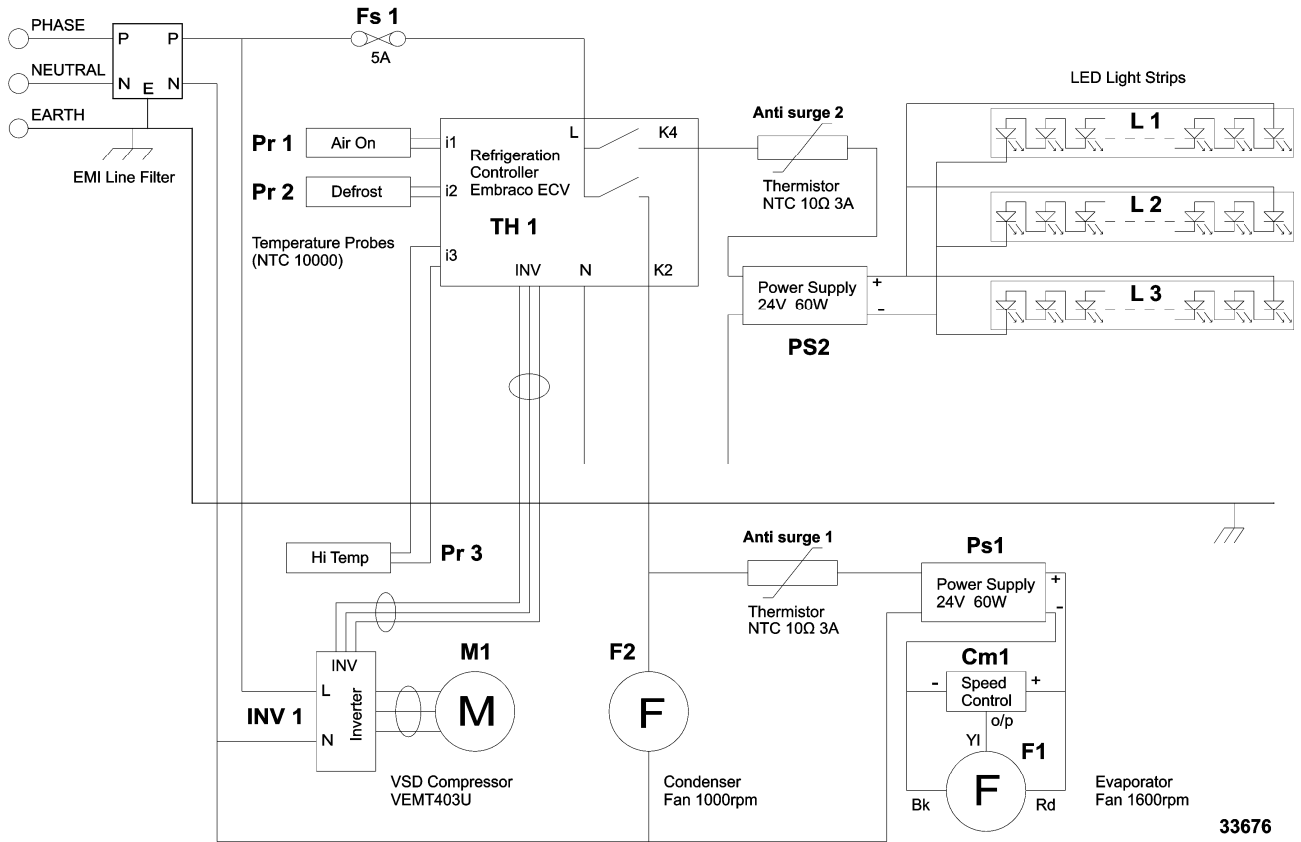

Model: IL-MD-900-REF-SQ Square Format Series, 900mm Refrigerated Horizontal Split Cabinet

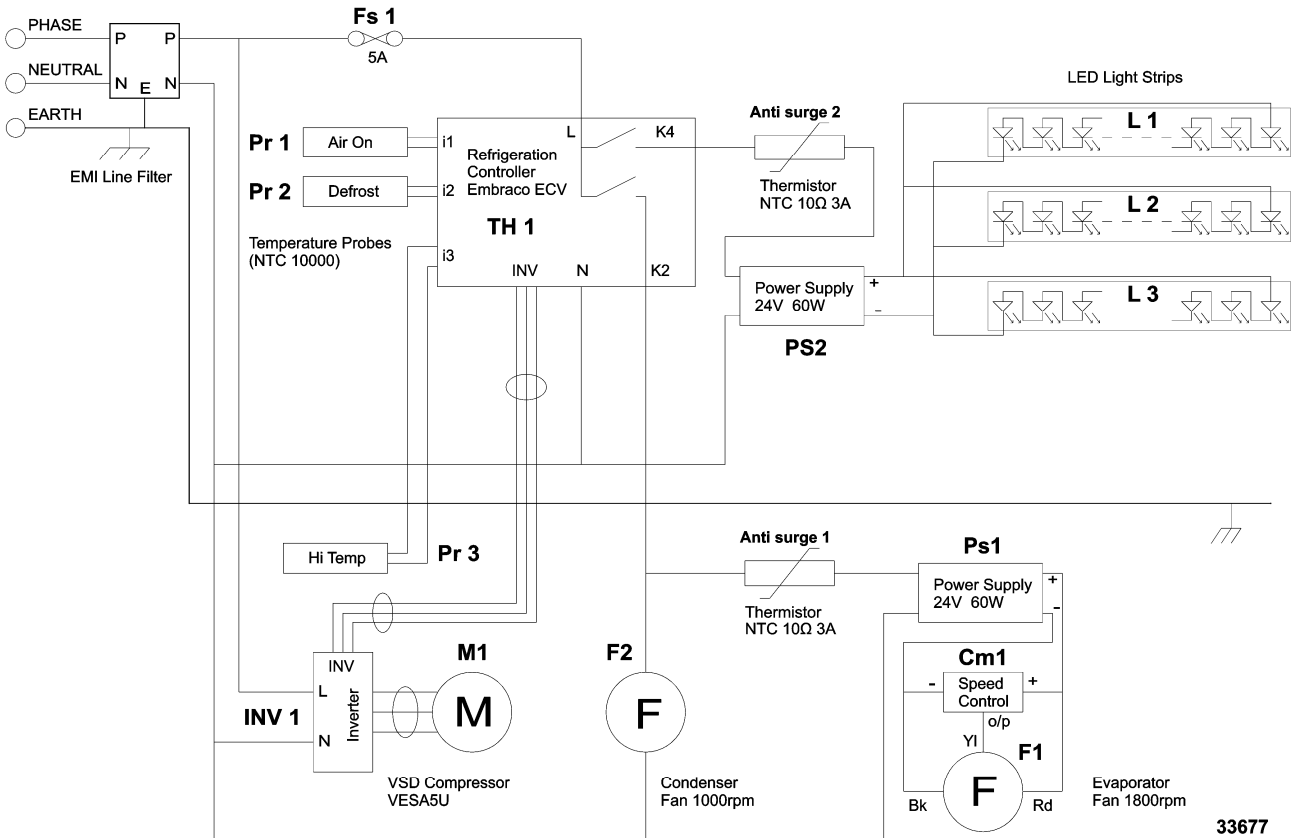

SPARE PARTS

Cabinet Serial Number

When ordering spare parts, it is important to quote the Serial Number printed on the label fixed to the control panel. This will enable FPG to trace details of the build specification of your particular cabinet, and hence ensure that spare parts are fully compatible.

To satisfy warranty conditions, and ensure optimum performance, use only FPG supplied spare parts.

Part Description	FPG Part No.
Fuse Link (5A, 250V, Slow Blow)*	13330
Ant-surge Thermistor 10 Ohm 3A*	22354
24V 60W LED power supply*	25473
Polycarbonate Top Light Cover, (600 cabinet)	25222
Polycarbonate Top Light Cover, (900 cabinet)	25223
Polycarbonate Divider Shelf Light Cover, (600 cabinet)	32907
Polycarbonate Divider Shelf Light Cover, (900 cabinet)	32908
Polycarbonate Bottom Shelf Light Cover, (600 cabinet)	33693
Polycarbonate Bottom Shelf Light Cover, (900 cabinet)	33694
Top/Divider Shelf Light Replacement Kit, (600 cabinet)	78257
Top/Divider Shelf Light Replacement Kit, (900 cabinet)	78259
Bottom Shelf Light Replacement Kit, (600 cabinet)	78258
Bottom Shelf Light Replacement Kit, (900 cabinet)	72440
Embraco Sync Controller (Frequency Coms 600/900 cabinets)*	78792
Embraco Sync Controller (Serial Coms 600/900 cabinets)*	78793
NTC temperature probe (Black, Defrost)*	79029
NTC temperature probe (Red, Hi Temp)*	79031
NTC temperature probe (Green, Air On)*	79028
Evaporator fan 24V dc *	32378
Condenser fan 172mm 1000rpm (600)*	78604
Condenser fan 200mm 1000rpm (900)*	78498
600 R290 VSD Refrigeration Kit, (Inverter/Compressor, fan and coil)*	78941
900 R290 VSD Refrigeration Kit, (Inverter/Compressor, fan and coil)*	78942
7mm Evaporator coil 600*	31511
7mm Evaporator coil 900*	31512
ACR Condensate Heat Exchanger*	33469

***Recommended Spare Parts to be carried by Service Provider**

CUSTOM

MCDONALDS INLINE

HORIZONTAL SPLIT CABINET/REFRIGERATED

Part Description	FPG Part No.
<i>All glass parts are double glazed</i> <i>Handed parts are identified as viewed from the rear of the cabinet</i>	
MD 600/900 LH End Glass Replacement Kit*	75181
MD 600/900 RH End Glass Replacement Kit*	75180
MD 600 Ref Front Glass Replacement Kit*	75142
MD 900 Front Glass Replacement Kit*	75179
MD 600 Ref Top Glass Replacement Kit*	75182
MD 900 Top Glass Replacement Kit*	75183
Shelf Front Air Baffle Panel, (600 cabinet)*	73319
Shelf Front Air Baffle Panel, (900 cabinet)*	73363
Divider shelf glass insert, (600 cabinet)*	27150
Divider shelf glass insert, (900 cabinet)*	26892
Rear Inner Sliding Door, (600 cabinet)*	71909
Rear Inner Sliding Door, (900 cabinet)*	71006
Rear Outer Sliding Door, (600 cabinet)*	71910
Rear Outer Sliding Door, (900 cabinet)*	71007
Slide-in rubber door seal	11424
Qlon door seal	12922
Rear vane flap replacement kit, (600 cabinet)*	75568
Rear vane flap replacement kit, (900 cabinet)*	75567
Plastic Air Grille*	12480
Black Acrylic Base Tray (600 cabinet)	27152
Black Acrylic Shelf Tray (600 cabinet)	29507
Bamboo Base Tray (600 cabinet)	28656
Bamboo Shelf Tray (600 cabinet)	29906
Black Acrylic Base Tray (900 cabinet)	26581
Black Acrylic Shelf Tray (900 cabinet)	29367
Bamboo Base Tray (900 cabinet)	29499
Bamboo Shelf Tray (900 cabinet)	29500
Tumbler/Tong Holder, Stainless Steel 100 x 80mm	30513
Product Manual for Square Format Refrigerated R290 VSD	33308

***Recommended Spare Parts to be carried by Service Provider**

MECHANICAL DRAWINGS

Model: IL-MD-600-REF-SQ-B100-01

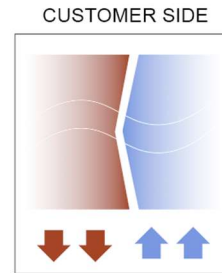
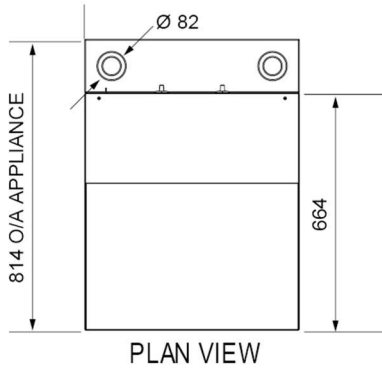

PLAN VIEW - AIRFLOW
FREEFLOW AIR TECHNOLOGY

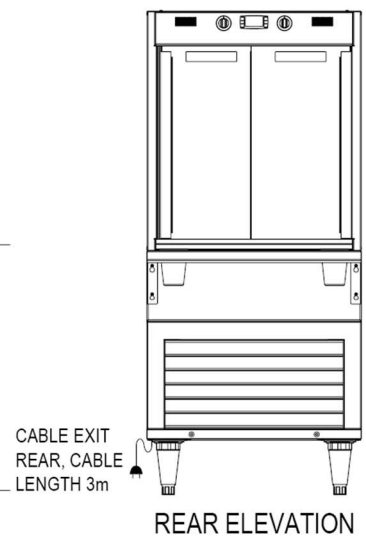
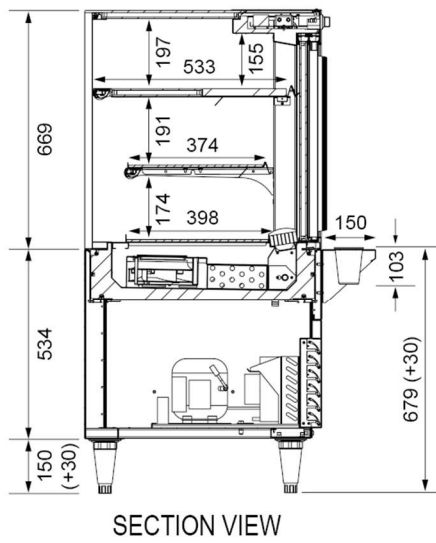
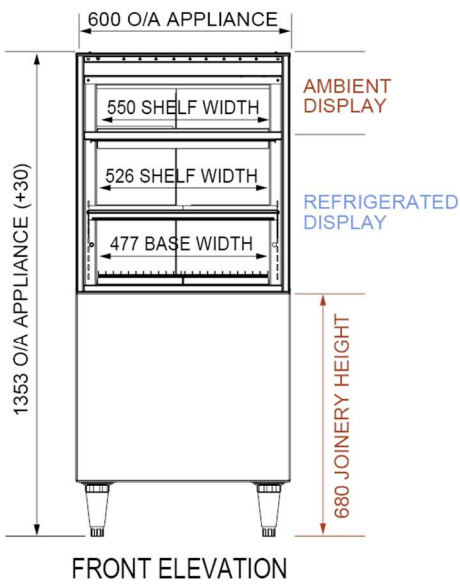

CUSTOM
 MCDONALDS INLINE
 HORIZONTAL SPLIT CABINET/REFRIGERATED

Model: IL-MD-900-REF-SQ-B100-01

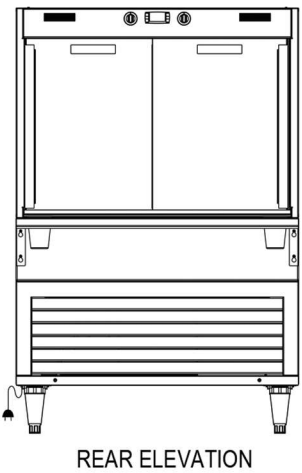
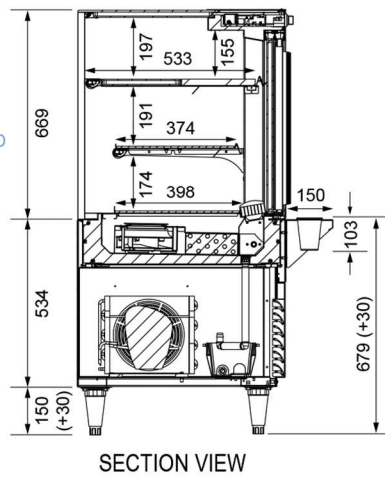
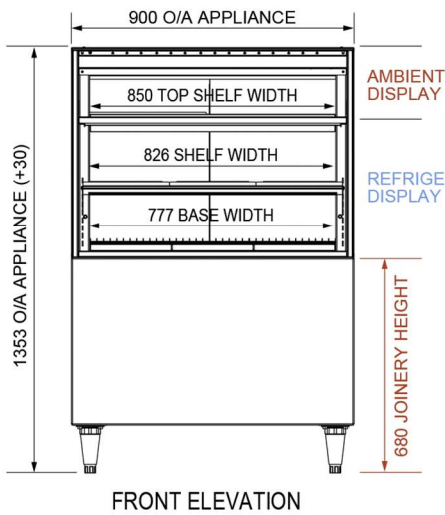
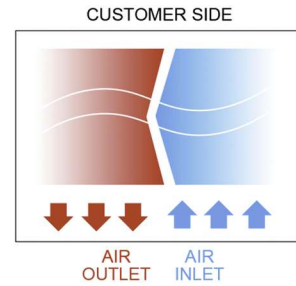
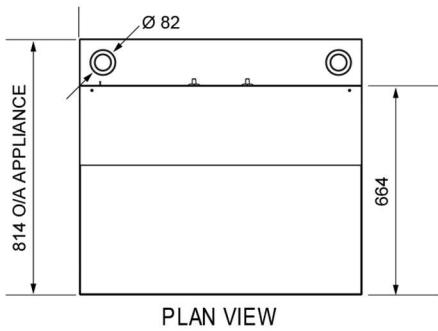

Door Seals

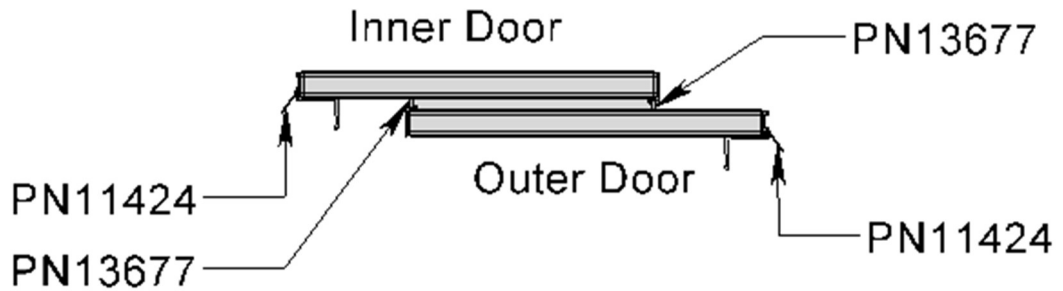

APPENDIX A R-290 Refrigerant

General Guidance

REFRIGERATED CABINETS - APPENDIX A
R-290 Refrigerant

R-290	<p>R-290 is the name for refrigerant grade high purity odorless propane. It is NOT barbeque grill propane. PROPANE IS HIGHLY FLAMMABLE. You MUST observe caution and proper safety practices when servicing equipment with R-290.</p>	
Servicing	Servicing refers to making repairs to the hermetically-sealed system and any parts of the electrical system.	
Specialized Training	Although not mandatory, specialized training of service personnel is desirable.	
Environment	Repair on R-290 equipment should always be done in a well ventilated area.	
Gas Detector	Because R-290 is highly flammable, an electronic combustible gas leak detector is required when servicing R-290 systems.	
Replacement Parts	When opening any refrigeration system, the filter/dryer must be replaced with the manufacturers specified spare part.	
Fault Diagnosis	Since there are no access fittings on R-290 systems, temperatures and current draw must be used to evaluate system performance.	
Check List	<p>Before proceeding with servicing, check the following:</p> <p>MONITOR: make sure the combustible-gas meter is on and in proper position.</p> <p>VENTILATE: make sure there is adequate ventilation in the work area.</p> <p>ELIMINATE: make sure to eliminate any potential ignition sources.</p>	

CUSTOM

MCDONALD'S INLINE
HORIZONTAL SPLIT CABINET/REFRIGERATED

Servicing

REFRIGERATED CABINETS - APPENDIX A
R-290 Refrigerant

Gas Monitor

Before entering any service area that may have hydrocarbons, always turn on a combustible gas monitor to alert you to the presence of flammable refrigerants while you are working.

Do not turn the combustible gas monitor off until you leave the service area.

Ignition

Do not unplug, disconnect power to, or begin servicing a system before checking for flammable refrigerants with the combustible gas monitor.

Sparks from unplugging or power disconnects could ignite flammable refrigerants.

Danger Sign

Display a Danger Propane placard to alert all that you are working on a R-290 system.

No open flames or smoking is allowed.

Instruct anyone in the immediate area the nature of the work taking place.

Be aware that E-cigarettes or similar electronic devices could be a source of ignition.



Fire Extinguisher

An approved fire extinguisher is required when servicing a system that contains a flammable refrigerant.

Access Fittings

Since access fittings are not supplied on any R-290 systems. Before adding access-fittings you should check temperatures and amps and contact FPG for guidance on fault finding.

Electrical Connectors



Wire nuts are not approved for R-290. All connectors must be UL approved for use with Hydrocarbons.

Wire connectors must have sufficient strength to hold the conductor/wire in place.

Replacement Components

When replacing components, ignition-proof sealed electrical components are required.

To avoid using unapproved parts, only FPG replacement parts are to be used on a R-290 system.

Tools

REFRIGERATED CABINETS - APPENDIX A
 R-290 Refrigerant

Basic Tools Use the same basic refrigeration tools as for R404-A & R-134a refrigerant.

Required Tools

	Combustible gas leak detector (Inficon Gas Mate) or equal		Propane warning notice
	Tubing cutter		Approved fire extinguisher (Class B dry powder type)
	Vacuum gauge		30cm charging hose (low Loss design)
	Ball charging valves (3)		Gram scale
	Tap valves 1/4" (2)		Digital thermometer
	Pinch off tool (2)		Venting hose

CUSTOM

MCDONALD'S INLINE
HORIZONTAL SPLIT CABINET/REFRIGERATED

Leak Checking

REFRIGERATED CABINETS - APPENDIX A
R-290 Refrigerant

Warning Do NOT use any leak test dyes when working on an R-290 refrigeration system.

Detection Methods

- Bubble test.
- Electronic combustible gas detection.
- Nitrogen holding pressure test (only possible on accessed systems).

For the most part, you would leak check a R-290 system the same way you would a R-134a or R-404A system with a couple of exceptions.

You cannot use a halide leak detector on an R-290 system, the electronic leak detector must be designed specifically for combustible gas.

Using oxygen-free dry nitrogen with a trace gas not exceeding 150PSIG is also recommended.





Accessing the Refrigeration System

REFRIGERATED CABINETS - APPENDIX A
R-290 Refrigerant

Installing Piercing Valves Line tap valves can be used to access the refrigeration system. Line tap valves should be temporarily placed on the suction and liquid process tubes.

IMPORTANT: Never leave piercing valves of any type on the R-290 refrigeration system. This would void the warranty.

Procedure

<p>Make sure the cabinet is disconnected from the power source.</p> <p>Wear safety glasses and gloves (rubber coated are best).</p>	
<p>Turn the combustible-gas leak detector "ON".</p> <p>Refer to the manufacturer's instructions for the detector you are using.</p>	
<p>Post the warning notice in plain view for all to see on the front and rear of the refrigeration appliance.</p>	
<p>Remove the red sleeves on the suction and liquid line process tubes.</p> <p>Install the piercing valves following manufacturer's instructions.</p> <p>Red sleeves must be replaced when done servicing.</p>	

Recovering Refrigerant

REFRIGERATED CABINETS - APPENDIX A
R-290 Refrigerant

Recovery Machines

Recovery machines for use with hydrocarbon refrigerants are in limited production.

Only an explosion proof recovery machine can be used to recover.

Procedure Without Machine

1. Evacuate an empty recovery cylinder into a vacuum.
2. Using an accurate refrigerant scale, zero out the refrigerant scale and weigh the empty recovery cylinder prior to adding refrigerant gauges or hoses. Note this weight.
3. Securely connect the evacuated cylinder to the refrigeration system using refrigerant gauges and hoses.
4. Open both refrigerant gauges to allow refrigerant to flow through the gauges to the recovery cylinder. You must evacuate from both sides.
5. Once the pressures have equalized, valve off the refrigerant gauges and the recovery cylinder securely.
6. Carefully remove the refrigerant hose from the recovery cylinder.
7. Zero out the refrigerant scale and weigh the recovery cylinder. Note this weight.
8. Subtract the empty tank weight recorded from the cylinder now containing the refrigerant. This will be the amount recovered.
NOTE: You can check Serial Label to verify any leak.
9. A recovery cylinder containing R-290 can be vented outdoors. See "Venting R-290" for instructions on venting R-290.
10. After venting the refrigerant, purge the recovery cylinder with nitrogen at a flow rate of 5PSIG through the liquid port of the recovery cylinder for 2 minutes outdoors, 3 metres away perimeter from any structures or ignition sources.
11. Repeat steps 1-9 until the recovery cylinder and the system equalize into a vacuum.

NOTE: Trace amounts of R-290 will remain trapped in the POE oil of the compressor.

CUSTOM

MCDONALD'S INLINE
HORIZONTAL SPLIT CABINET/REFRIGERATED

Venting R-290

REFRIGERATED CABINETS - APPENDIX A
R-290 Refrigerant

- | | |
|---------------------------|--|
| Venting Procedures | <ol style="list-style-type: none">1. Do NOT vent hydrocarbon refrigerants inside a building under any circumstance (SAFETY RISK).2. Venting hydrocarbon refrigerants to a public area or where people are unaware of the procedure is not permitted.3. When venting R-290 YOU MUST make everyone in the immediate area aware that you are venting a flammable gas to the atmosphere.4. Ensure there are no ignition sources within a 10 ft. perimeter of the area you are venting R-290. Be aware that E-cigarettes or similar electronic devices could be a source an ignition.5. Ensure that all local legislation/regulations addressing safety of hazardous or flammable substances are satisfied.6. Ensure you are not venting R-290 into a low-lying area. R-290 is heavier than air and can accumulate in floor drains, grease traps, piping troughs, etc.7. After venting, purge with Nitrogen through the system for a minimum of 10 seconds. |
|---------------------------|--|
-

System Evacuation

REFRIGERATED CABINETS - APPENDIX A
R-290 Refrigerant

- | | |
|--------------------------|--|
| Preliminary Tasks | <p>Prior to sealing up the system make sure you have a sufficient amount of service access tubing remaining for service in the future.</p> <ol style="list-style-type: none">1. Remove the crimped tubing and piercing/saddle valve from the process tube.2. Extend the process tube a minimum of 30cm.3. Crimp and braze the process tube extension.4. Install piercing/saddle valve just before last crimp. <p>After the system has been sealed and leak checked, it is necessary to evacuate it in order to remove air, moisture, and unwanted residual refrigerant.</p> |
|--------------------------|--|
-

NOTE	Technician must use tube cutter instead of torch when removing refrigeration system components.
-------------	--

System Evacuation cont.

REFRIGERATED CABINETS - APPENDIX A
R-290 Refrigerant

- | | |
|-----------------------------|---|
| Evacuation Procedure | <ol style="list-style-type: none"> 1. It is necessary to purge the system with nitrogen. This is necessary to prevent flammable mixtures from occurring. 2. When connecting the hoses between the system, gauge manifolds, and vacuum pump, ensure that the connections are secure and there are no potential ignition sources nearby. 3. Ensure that the pump discharge is in an area free of potential ignition sources. 4. Ensure that a micron gauge is used since conventional manifold gauges may not provide a proper reading. 5. The system should be evacuated to the desired pressure (typically 250 microns or less) and then left to stand for 15 minutes to ensure that the entire refrigerant charge has been removed from the oil and any residual moisture has been evaporated from the system. 6. Ensure that the vacuum pump is of good quality and of appropriate capacity for the system, and the oil level is correct. |
|-----------------------------|---|

Charging the System

REFRIGERATED CABINETS - APPENDIX A
R-290 Refrigerant

WARNING	Dial-a-charge cylinders, with a sight glass, should not be used to charge systems with flammable refrigerant.
----------------	--

- | | |
|--------------------|--|
| Precautions | <p>Although charging procedures are similar to those used with any other type of refrigerant, the following considerations are important for R-290:</p> <ul style="list-style-type: none"> • Prior to charging, ensure the system has been leak checked. • Hoses or lines must be as short as possible to minimize the amount of refrigerant contained in them. • Evacuate the hoses and manifold prior to charging to avoid contamination of the refrigerant. • Upon completion of charging, a further leak check must be carried out prior to leaving the site. • After charging, carefully disconnect the hoses, attempting to minimize the release of refrigerant. • After charging, all access ports/points must be removed following the correct procedures. |
|--------------------|--|

**DO NOT OVERCHARGE A SYSTEM USING R-290.
Weigh in the exact charge.**

CUSTOM

MCDONALD'S INLINE
HORIZONTAL SPLIT CABINET/REFRIGERATED

Removal and Sealing of Access Ports

REFRIGERATED CABINETS - APPENDIX A
R-290 Refrigerant

CAUTION **Do not leave piercing valves on the system.**

Procedure

1. Pinch line off just before the temporary access port two times using a crimping tool. Keep crimping tool in place as shown in photo.
2. Verify that there are no leaks.
3. Remove the piercing valve/temporary access port.
4. Snap off at "crimp 1" and check for leaks.
5. Braze open end shut while crimping tool is in place.
6. Leak check the system, with crimping tool removed.



Electrical Repairs

REFRIGERATED CABINETS - APPENDIX A
R-290 Refrigerant

CAUTION The electrical power to the equipment must be disconnected. A combustible-gas leak detector must be on at all times.

Protect yourself from hazards of working on the electrical components by following some basic guidelines before you begin the repair. Prior to starting your repair work on an electrical component, use your combustible gas detector to see if flammable gas is present.

Only when the area is clear of any flammable gas should you start the repair.

Guidelines

- Do not use components that produce sparks, discharge, etc.
 - Components that could produce a potential ignition source need to be positioned in an area, distant and unreachable, from any potential refrigerant leak.
 - FPG components are designed for use with flammable refrigerants.
 - Do not replace faulty components that are intended not to spark with components that do. ONLY use FPG recommended spares.
 - Do not modify components that are intended not to spark in such a way that they will spark.
-

Electrical Repairs cont.

REFRIGERATED CABINETS - APPENDIX A
R-290 Refrigerant

Check General Condition

You may not be the first person that has worked on this system.

- Check all components for unauthorized/non-OEM replacement parts.
 - Look beyond your repair for any wear, stresses, that could become an ignition source. Are terminal connections tight and in a UL approved connectors?
 - Check all protective conductors' connections each time you access a system or repair is made.
 - Finally, check the plug, cabling and wiring for any damage.
-

CUSTOM

MCDONALD'S INLINE
HORIZONTAL SPLIT CABINET/REFRIGERATED

R-290 SERVICING FLOW CHART

Before starting work on the R-290 system, turn on the gas-leak detector and place it on the floor, next to the cabinet.

	Refrigeration Circuit Access	Comments
1	Disconnect electrical supply to appliance.	If possible, ground the appliance to avoid static electric sparks.
2	Access condenser/compressor and install two piercing valves.	Vent both the high and low side of the system in case there is a blocked cap tube and/or drier.
3	Connect your refrigeration gauge equipped with 30cm hoses to the two piercing valves.	
4	Connect the yellow hose of your gauge set to a recovery bag or a venting tube, if a safe venting location is available.	
5	Once the charge is removed, connect the Nitrogen tank.	
6	Purge Nitrogen through the system for a min. of 10 seconds.	If using a recovery bag, be sure to take it to a safe location and vent.
7	Always cut the compressor or other components out with a tubing cutter.	
8	Purge Nitrogen through the system at 70 to 140 hPa, before any parts must be un-brazed.	
9	Purge Nitrogen through system at 70 to 140 hPa, while brazing in new components.	

	Installing New Components	Comments
1	Remove old compressor, drier and any other defective component.	If the compressor is removed, seal the suction and discharged tubes to prevent a spill.
2	Install new FPG approved spare parts.	A new dryer must be fitted if the compressor is replaced.
3	If the two access line tubes are not at least 30cm long, add more tube with brazed pinched-off ends. Reinstall tap valves.	Access tubing lines may need to be braced to prevent bending over.
4	Purge with Nitrogen again at 70 to 140 hPa while brazing. Wrap drier with wet rag when brazing.	
5	Fill the system with Nitrogen to 1000 kPa and check for leaks.	
6	Release Nitrogen and pull a vacuum on the system to 250 microns or less. Turn off the vacuum and confirm that it holds the vacuum.	
7	If vacuum holds, the system can now be charged.	Propane labelled 'R-290 Refrigerant' must be used. DO NOT USE BBQ PROPANE.
8	Purge the charging hoses and ready your gauge set and hoses so they will not move during the charging process.	
9	Check the cabinet Serial Number label for the required charge.	
10	Use the ball valves installed on your hose to meter in the charge.	Because the charge is small, take care and be precise.
11	Charge the circuit. (preferred method of charging is to charge liquid into liquid line).	
12	If new starting components have been fitted, check electrical connections and install all terminal covers.	FPG compressor start components are designed for use with HC refrigerants. Do not use non-FPG approved spare parts.
13	Start the system and check operation. Do a final check for leaks	

REFRIGERATED CABINETS

CUSTOM

MCDONALD'S INLINE
HORIZONTAL SPLIT CABINET/REFRIGERATED

Revision History

Revision Level	Date of Change	Change Details
A	22/11/23	New manual for R290 VSD cabinet
B	05/07/24	Circuits and manual revised to use Embraco Sync refrigeration controller
	18/11/24	Spare parts table updated with new items and P/Ns.

PRODUCT MANUAL 333

REV C NOV 2024

In line with our policy to continually develop, improve and support our products, Future Products Group Ltd reserves the right to change specifications and design without notice.

Have a question? Please email us at: sales@fpgworld.com or visit www.fpgworld.com for full contact details for your region.

