



INLINE SERIES - 3000 AMBIENT 900mm SQUARE IN COUNTER

MODELS

- IN-3A09-SQ-FF-IC | 3000 Series ambient 900mm square, with fixed front glass, in counter
- IN-3A09-SQ-SD-IC | 3000 Series ambient 900mm square, with sliding glass doors, in counter

OPTIONS [F=Factory Fitted]

- LED lighting to shelves (F)

ACCESSORIES [A=Accessory]

- Toughened glass shelves (A)
- Angled base shelf (A)
- Thermal divider panels (A)
- Wire shelves (A)
- Rear decks (A)

OVERVIEW

Created as a medium duty solution for café, kiosk and c-store, these cabinets provide a plug and go solution that allows 60 door openings per hour while maintaining core product temperatures. Packaged with the same key benefits of the FPG product range, you use less energy while still maintaining food safety. The Inline 3000 construction allows for smart counter integration options of either a recessed, countertop mounting or freestanding display.

FEATURES

- High energy efficiency - 0.02 kWh per hour average
- Cabinet operating at ambient temperature
- Sliding doors (staff side) and fixed front or sliding doors options (customer side)
- Fan assist air circulation to introduce fresh air into the cabinet
- Two adjustable shelves and base for product display
- 50,000 hour LED lighting to cabinet top and optional shelf lighting available
- Unique shelf mounted ticket strip front and rear
- Fully double glazed for energy efficiency
- Also available as a on counter model or a freestanding model with a chassis



SHOWING : 3000 SERIES AMBIENT 900mm SQUARE, WITH FIXED FRONT, IN COUNTER

KEY SELLING FEATURES



IN-3A09-SQ-FF-IC	ENVIRONMENTAL TEST CONDITIONS	25°C / 60% RH	TEMPERATURE RANGE	Ambient
IN-3A09-SQ-SD-IC				

Designed to meet and exceed the following compliances and approvals : NSF, EN 55014, EN55014-1, EN 55014-2, EN 61000, EN 61000-3-2, EN 61000-3-3, IEC 60335, IEC 60335-1.



VIEW ONLINE AT FPGWORLD.COM



INLINE SERIES - 3000 AMBIENT 900mm SQUARE IN COUNTER

SPECIFICATIONS

Ambient Data

	ENVIRONMENTAL TEST CONDITIONS	CORE PRODUCT - TEMP RANGE
IN-3A09-SQ-FF-IC	25°C / 60% RH	Ambient
IN-3A09-SQ-SD-IC	25°C / 60% RH	Ambient

Electrical Data

	VOLTAGE	PHASE	CURRENT	kWh per hour [average]	MAINS CONNECTION	MAINS CONNECTION PLUG	IP RATING	LED LIGHTING
IN-3A09-SQ-FF-IC	220-240 V	Single	0.11 A	0.02 kWh per hour	3 metre 3 core cable	10 amp, 3 pin plug	IP 22	50,000 hr LED
IN-3A09-SQ-SD-IC	220-240 V	Single	0.11 A	0.02 kWh per hour	3 metre 3 core cable	10 amp, 3 pin plug	IP 22	50,000 hr LED

Display

	DISPLAY AREA	NO. OF SHELVES	ACCESS - FRONT	ACCESS - REAR	CONSTRUCTION
IN-3A09-SQ-FF-IC	0.85m ²	2 + Base	Fixed front	Sliding doors	304 Stainless Steel
IN-3A09-SQ-SD-IC	0.85m ²	2 + Base	Sliding doors	Sliding doors	304 Stainless Steel

Dimensions [Uncrated and Crated]

	H x W x D mm [Uncrated]	MASS [Uncrated]	H x W x D mm [Crated]	MASS [Crated]	CUBIC VOLUME [Crated]
IN-3A09-SQ-FF-IC	774 x 900 x 662	52 kg	934 x 974 x 736	94 kg	0.67m ³
IN-3A09-SQ-SD-IC	774 x 900 x 662	52 kg	934 x 974 x 736	94 kg	0.67m ³

Installation note:

Model cutout dimensions:

- IN-3A09-SQ-FF-IC and IN-3A09-SQ-SD-IC models require 878 x 650mm benchtop cutout (see product manual for installation guide)

In line with policy to continually develop and improve its products, Future Products Group reserves the right to change specifications and design without notice.

For more information and technical data, including installation documents, please refer to the website - www.fpgworld.com

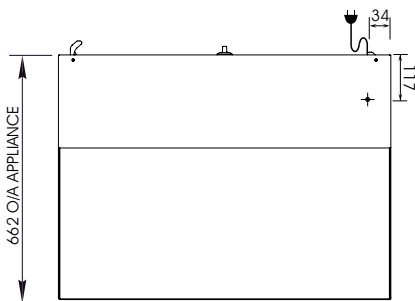

PLAN VIEW

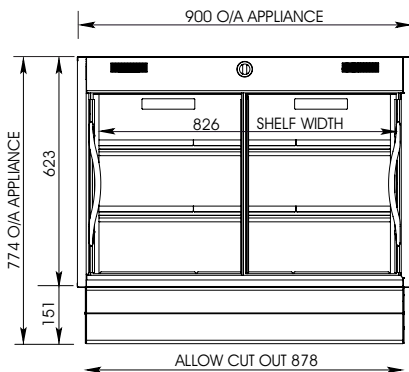

FRONT ELEVATION

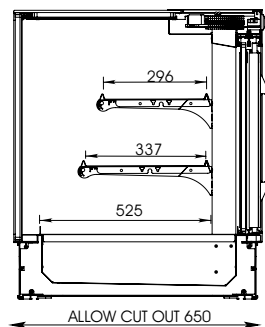

SECTION VIEW

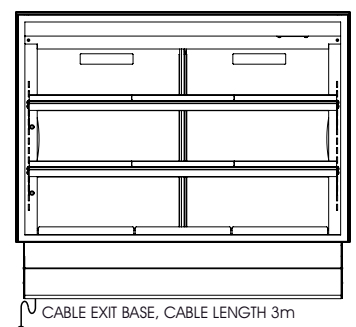

REAR ELEVATION